



Telecab

RESIDENTIAL ELEVATOR

Planning Guide

Applicable Codes:

ASME A17.1/CSA-B44

Safety Code for Elevators and Escalators

Section 5.3 – Private Residential Elevators

Part No. 000698
24-m09-2015

Copyright © 2015
Savaria Corporation
All rights reserved.

Printed in Canada

Purpose of This Guide

This guide assists architects, contractors, and lift professionals to incorporate the Telecab Residential Elevator into a residential building design. The design and manufacture of the Telecab Residential Elevator meets the requirements of the following codes and standards:

ASME A17.1-1996 Section 5

CAN/CSA B44-2010 Section 5.3

We recommend that you contact your local authority having jurisdiction to ensure that you adhere to all local rules and regulations pertaining to residential elevators.

IMPORTANT: This Planning Guide provides nominal dimensions and specifications useful for the initial planning of a residential elevator project. Dimensions and specifications are subject to change without notice due to continually evolving code and product applications.

Before beginning actual construction, please consult Savaria Corporation or the authorized Savaria dealer in your area to ensure you receive your site-specific installation drawings with the dimensions and specifications for your project.

Visit our website for the most recent Telecab drawings and dimensions.

How to Use This Guide

- 1 Determine your client's intended use of the lift.
- 2 Determine the local code requirements.
- 3 Determine the site installation parameters.
- 4 Determine the cab type and hoistway size requirements.
- 5 Plan for electrical requirements.

History

December 11, 2009 – Initial release

April 6, 2010 – Updated logo and typeface

October 14, 2010 – Updated all cab type information and drawings

March 31, 2011 – Corrected travel speed in specifications table on page 4

July 8, 2013 – Added Noise Level to specifications table on page 4

January 2, 2014 – Revised text in drawing on page 5

February 6, 2014 – Removed outdated Architect Specification section (was pages 17-19)

March 12, 2014 – Revised Specifications table on page 4

April 21, 2014 – Revised Specifications table on page 4

November 5, 2014 – Revised Applicable Codes on page 3

September 24, 2015 – Added Daily Cycle to specifications table on page 4

Specifications

Telecab Specifications

Specification	Specification Data
Load capacity	500 lbs. (227 kg)
Maximum travel	20 ft (6.0 m) with two stops
Travel speed	20 ft/min (0.1 m/s)
Noise level (for typical installation)	72.9 dBA (up direction); 50.0 dBA (down direction) Measured at a height of 1m, distance of 1m, in front of the motor with all panels on
Daily cycle	Normal: 30 Heavy: 75 Excessive: 100 Maximum starts in 1 hour on standard installation: 12 NOTE: Please consult your Sales Representative if there a chance you may exceed these amounts.
Tower	Modular 8 ft (2.4 m) guide rail assembly with roller guide shoes
Control system	115 VAC relay logic operation 115 VAC up direction and 12 VDC down direction
Levels serviced	2 levels
Platform	Non-skid platform
Power supply (circuit supplied by others)	110 VAC, 20 A, 60 Hz, single phase
Lighting supply (circuit supplied by others)	120 volt, 60 Hz, single phase
Motor/pump	120 VAC, 1.0 HP geared type
Electrical	Automatic battery recharging system (115 VAC) Low voltage controls
Drive system	2:1 roller chain hydraulic
Temperature operating range	-10 °C to +40 °C (14 °F to 104 °F)
Cab access	Front access only (standard) Left or right access (optional); with optional 2-door access
Cab dimensions	Standard: W30" x L46" x H78" (762 mm x 1168 mm x 1981 mm) Optional: W32" x L53" x H78" (813 mm x 1346 mm x 1981 mm) Optional: W30" x L47" x H78" (762 mm x 1194 mm x 1981 mm) Optional: W32" x L54" x H78" (813 mm x 1372 mm x 1981 mm) Optional: W36" x L59" x H78" (914 mm x 1499 mm x 1981 mm)
Door size	H78" x W30" steel with Plexiglas insert
Minimum overhead clearance	92" (2337 mm)
Hall calls	Continuous pressure directional push buttons Keyed call/send
Color and finish	White electrostatic powder coat Clear or bronze acrylic windows
Safety features	Adjustable top floor presence detector built into the cab Electromechanical door lock and open door sensor Underpan safety sensor Emergency stop and alarm Emergency battery lowering Manual emergency lowering Fully-enclosed drive tower Pressure relief valve to prevent platform overload Slack chain safety device Two halogen lights in cab Telephone in cab
Optional equipment	Battery operation in up and down directions Two door concept (left/right access) Custom cab size (without ABS vacuum formed plastic finish) Custom color Horizontal plastic panel on hinged side Wired remote control in cab Hydraulic door closer Automatic door operator (without ABS vacuum formed plastic finish) Keyed call station Flush-mount or surface-mount call/send station Optional 24-volt battery model

Site Construction Details

The Telecab needs a wall that supports a minimum of 700 lb (3114 N) of pull-out force at any bracket. The floor must be capable of supporting a load of 3200 lb (14.2 kN). See Figure 1.

A support wall with a combination of either two columns of three 2x4's, two columns of two 2x4's and two 2x6's, or a concrete or brick wall is required. Figure 2 shows the support wall configuration

Figure 1: Wall/floor loading

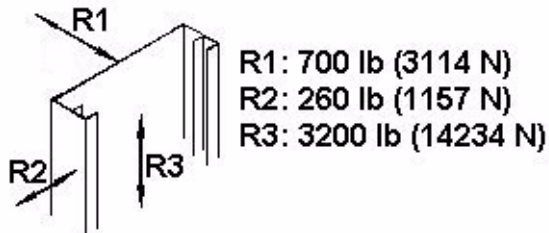
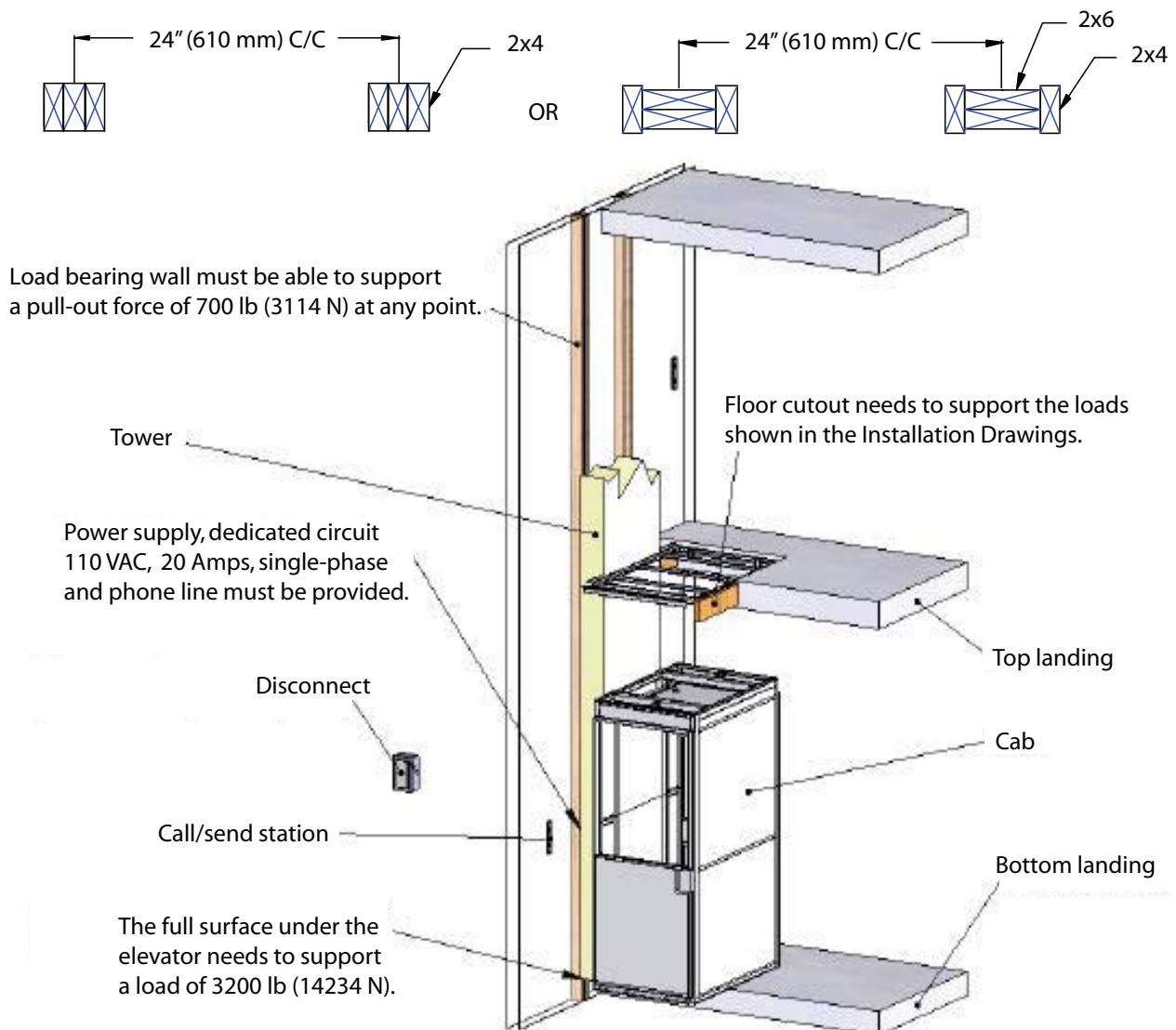

Figure 2: Support wall configuration



Elevation View

The following illustration shows the general elevation view and dimensions of the Telecab. Note that the minimum overhead is 90" for a 78" inside height cab dimension.

Refer to your site-specific Installation Drawings for details relevant to your job site.

Figure 3: Elevation view and dimensions

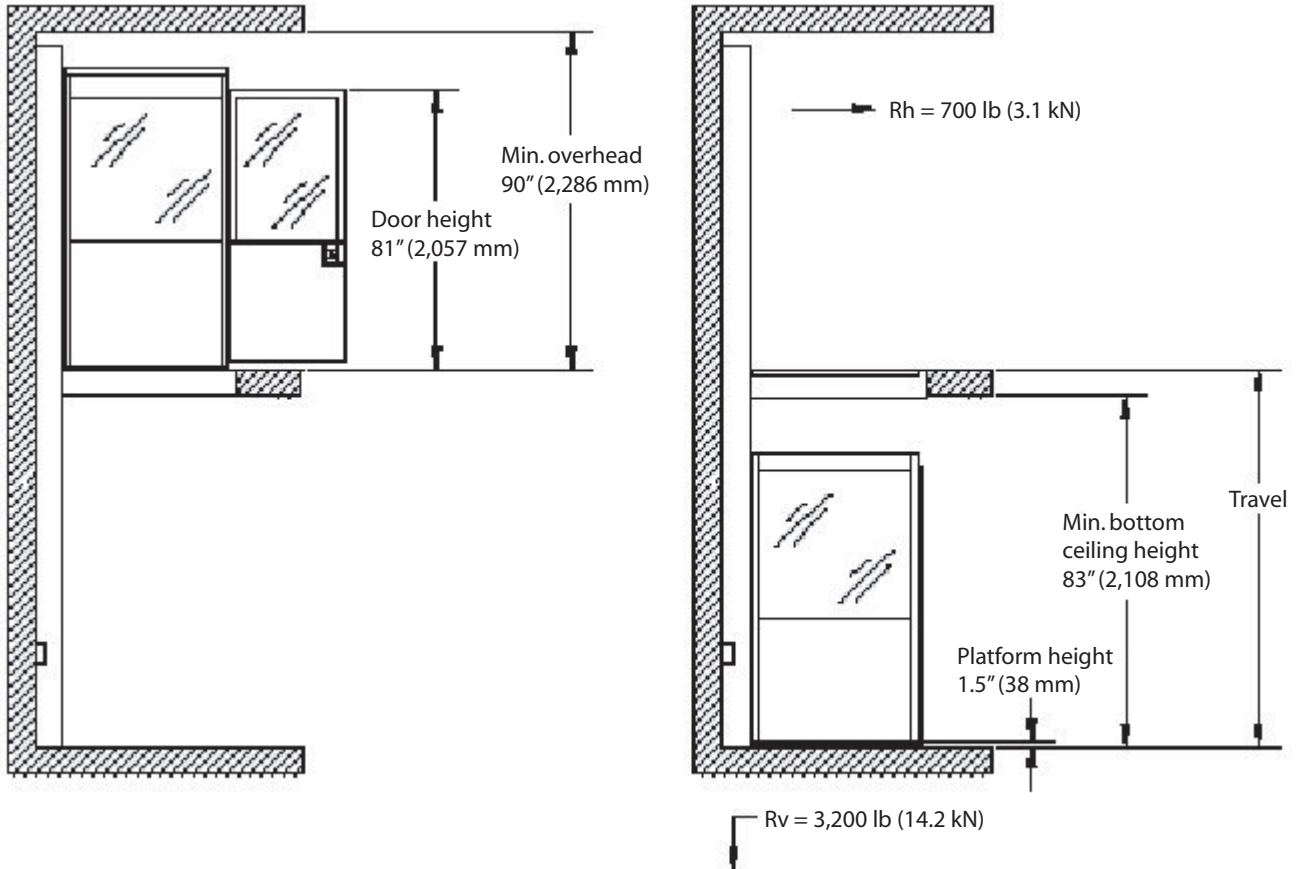

Cab Types

Cab types and sizes are listed below. Always refer to your site-specific Installation Drawings for details.

- Type 5 – 30" x 46", front access only (standard)
- Type 5 – 32" x 53", front access only (optional)
- Type 1L– 30" x 47" or 32" x 54", left access (optional)
- Type 1R– 30" x 47" or 32" x 54", right access (optional)
- Type 2– 30" x 47" or 32" x 54", left or right access (optional)

Figure 4: Cab types

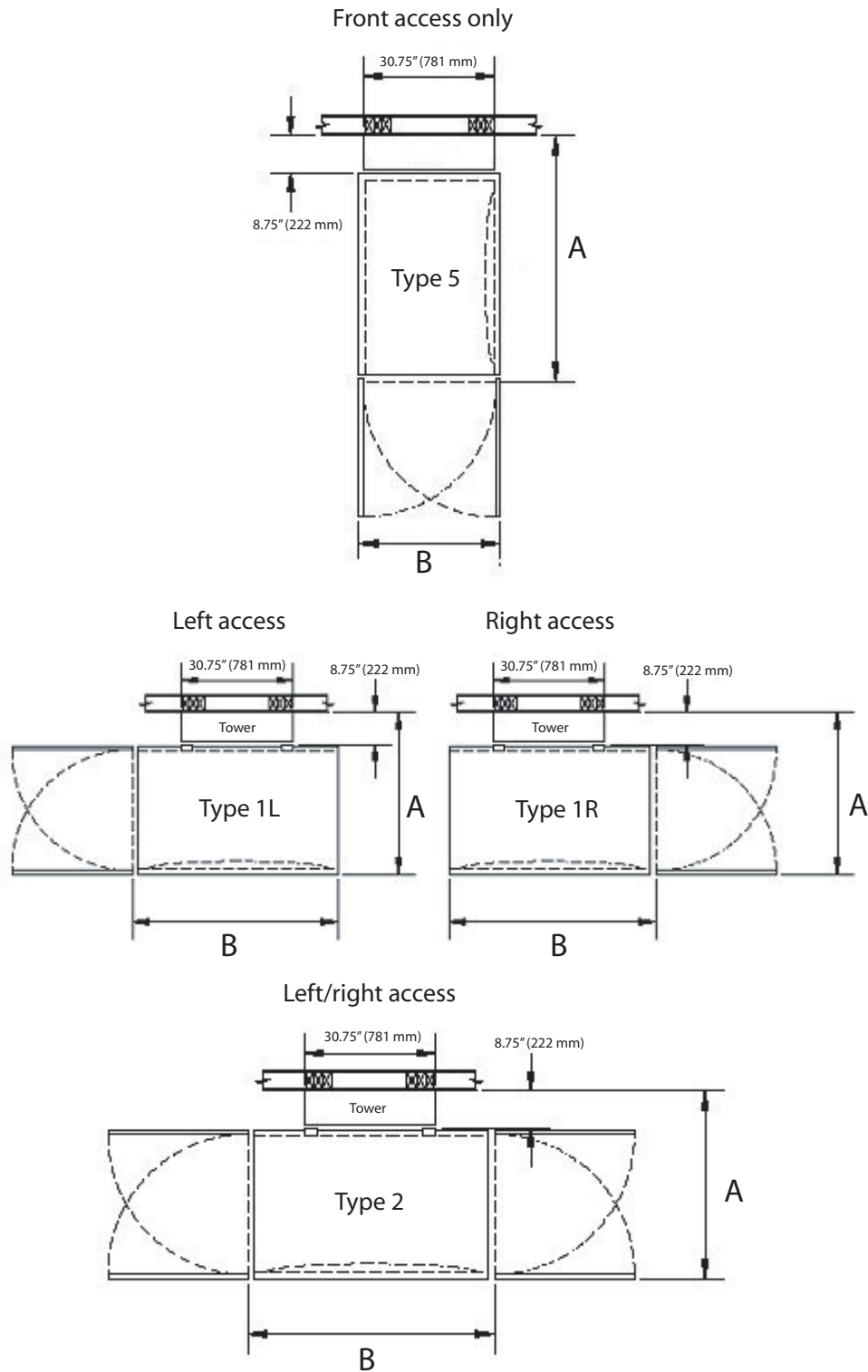

Drawings

The next several pages provide installation drawings for the Telecab.

- Type 5– 30" x 46", front access only
- Type 5 – 32" x 53", front access only
- Type 1L – 30" x 47", left access
- Type 1L – 32" x 54", left access
- Type 1R – 30" x 47", right access
- Type 1R – 32" x 54", right access
- Type 2 – 30" x 47", left/right access
- Type 2 – 32" x 54", left/right access

Figure 5: Type 5 – 30" x 46", front access only

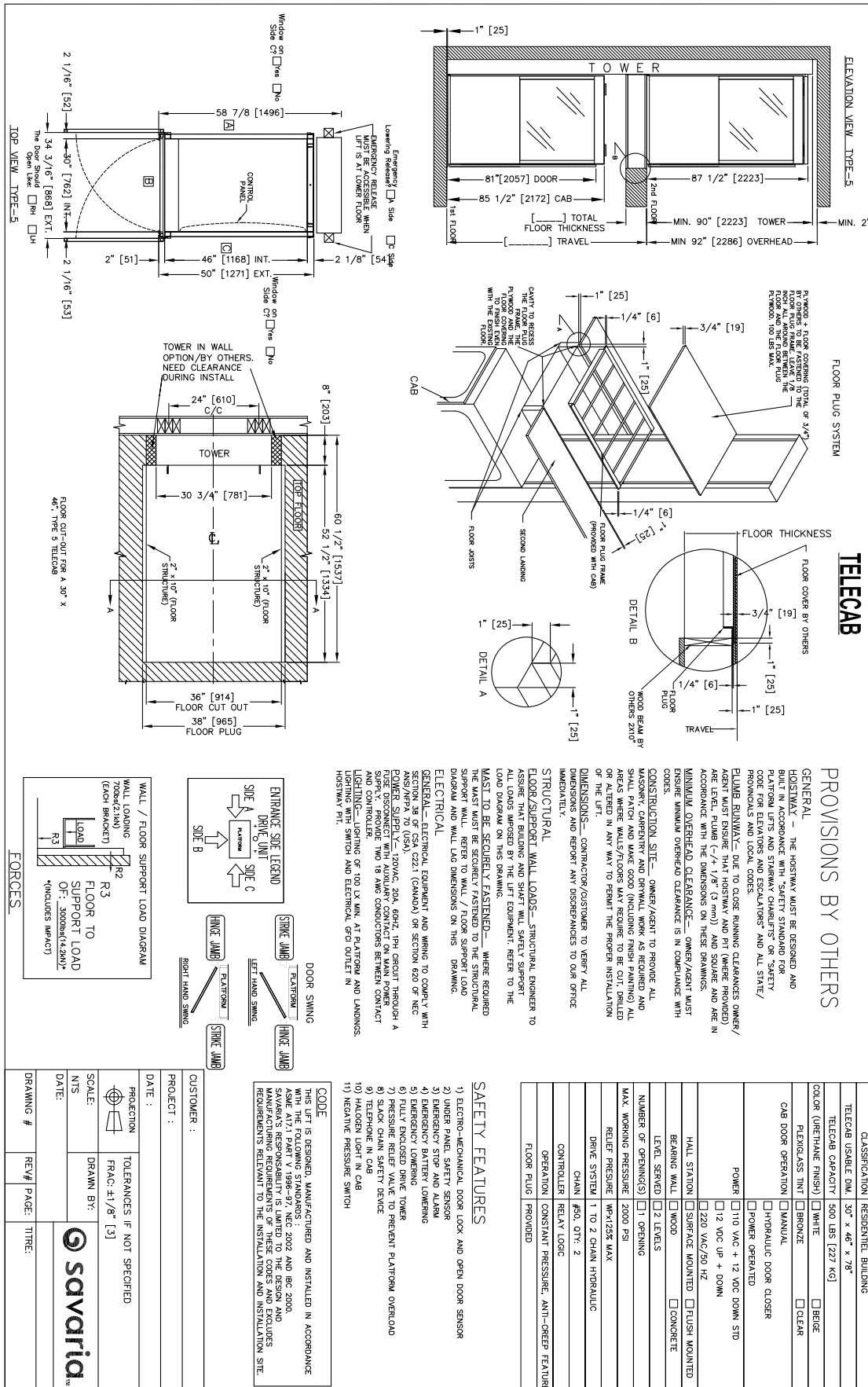

Figure 6: Type 5 – 32" x 53", front access only

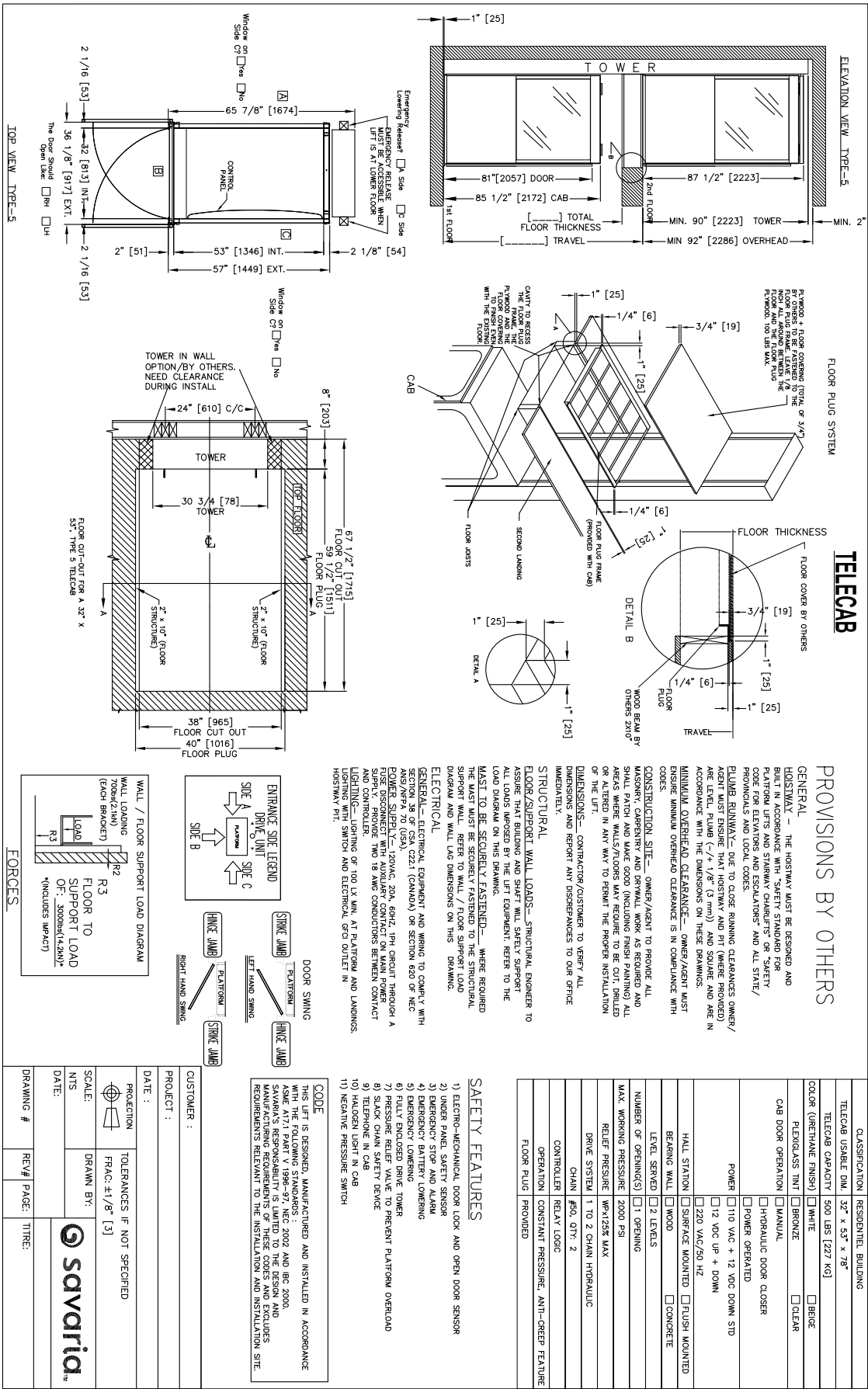

Figure 7: Type 1L – 30" x 47", left access

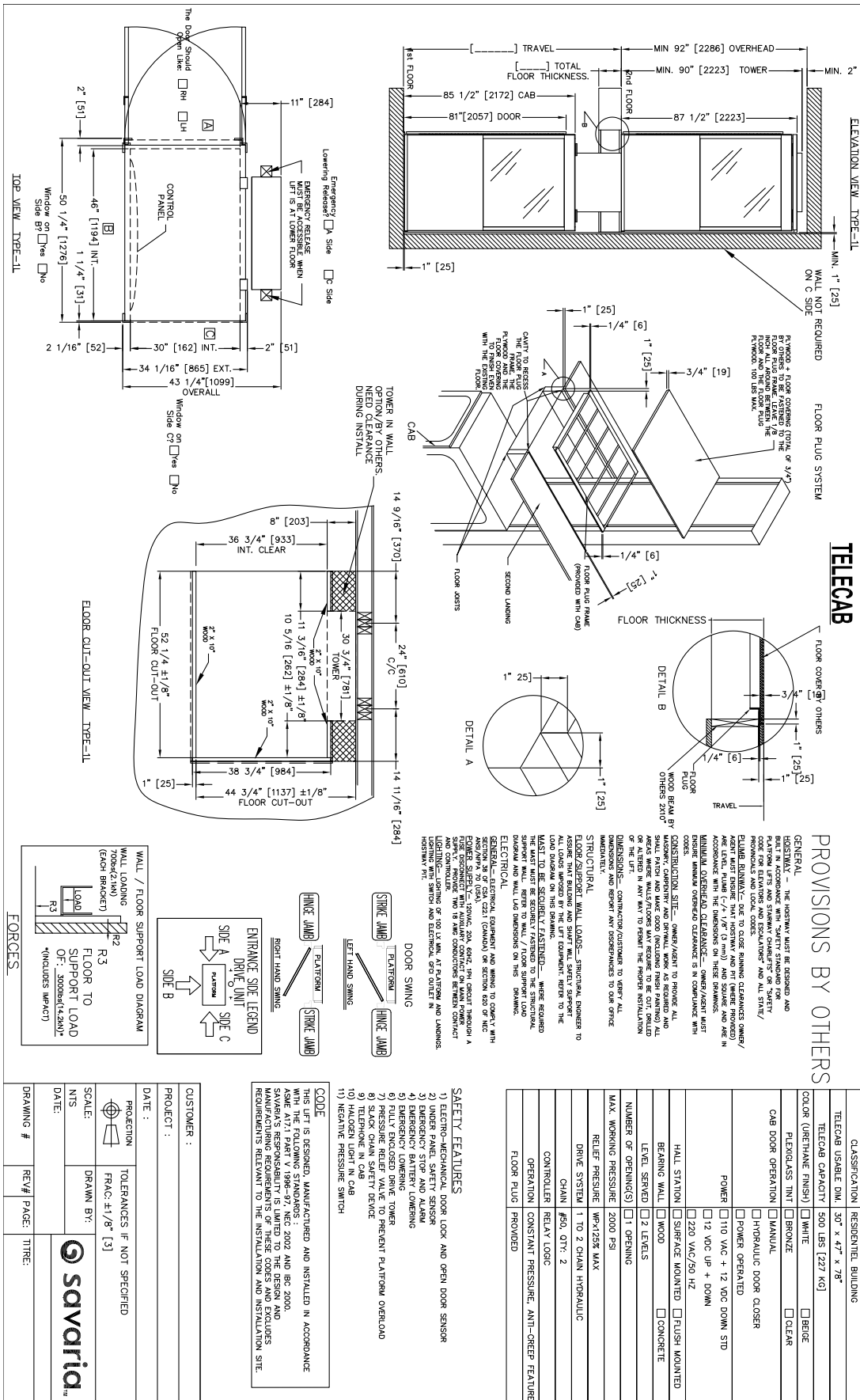

Figure 8: Type 1L – 32" x 54", left access

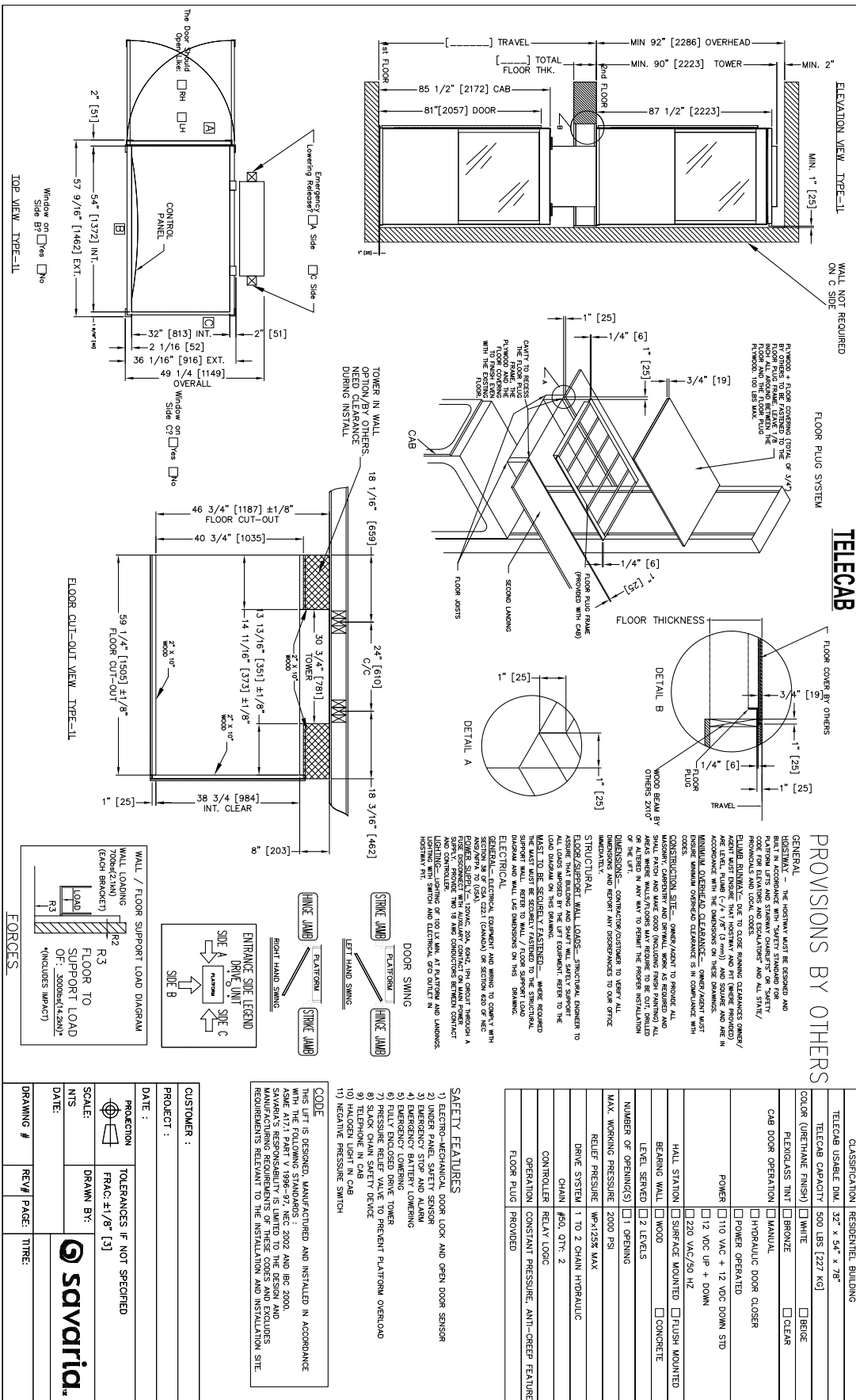

Figure 10: Type 1R – 32" x 54", right access

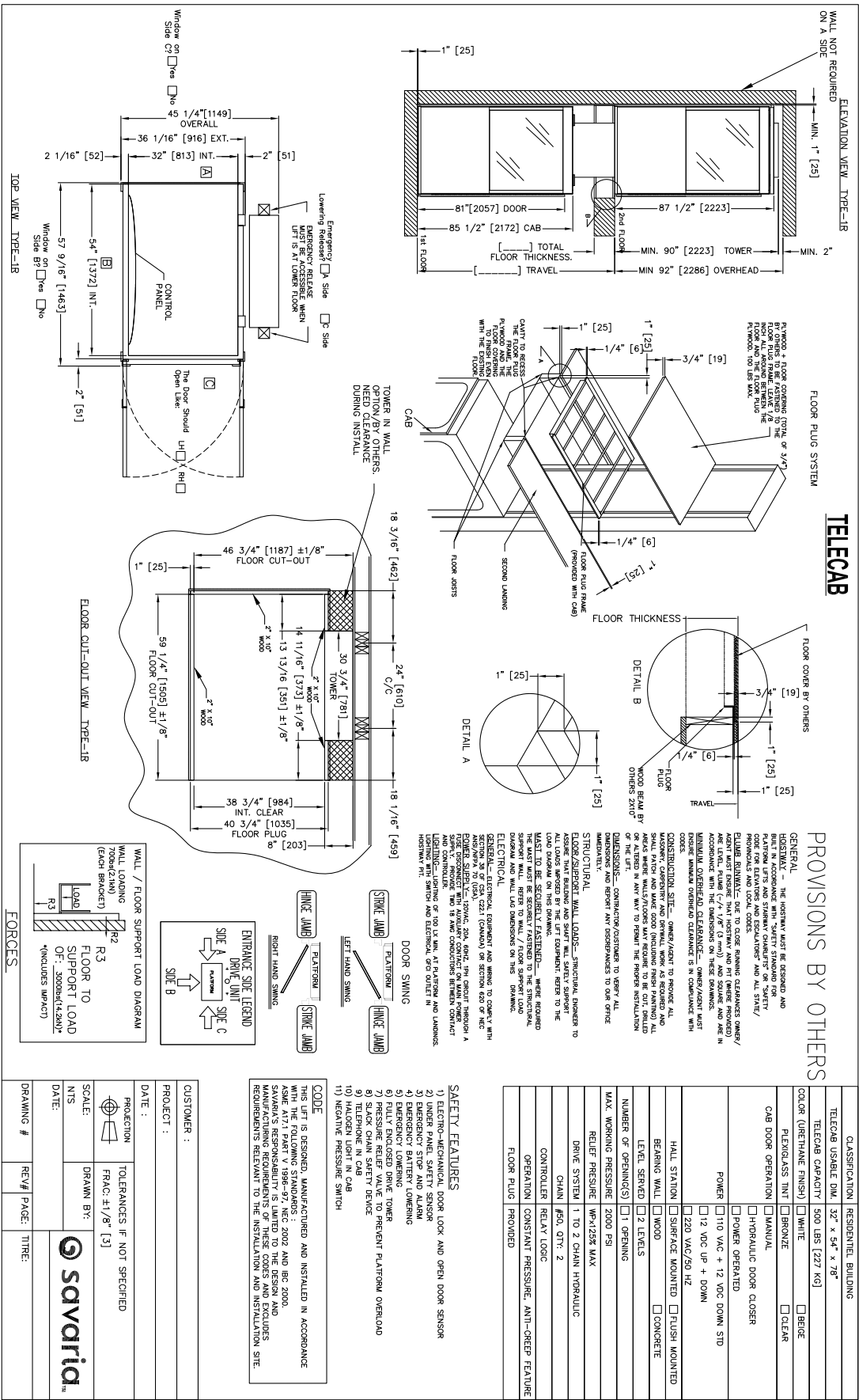

Figure 11: Type 2 – 30" x 47", left/right access

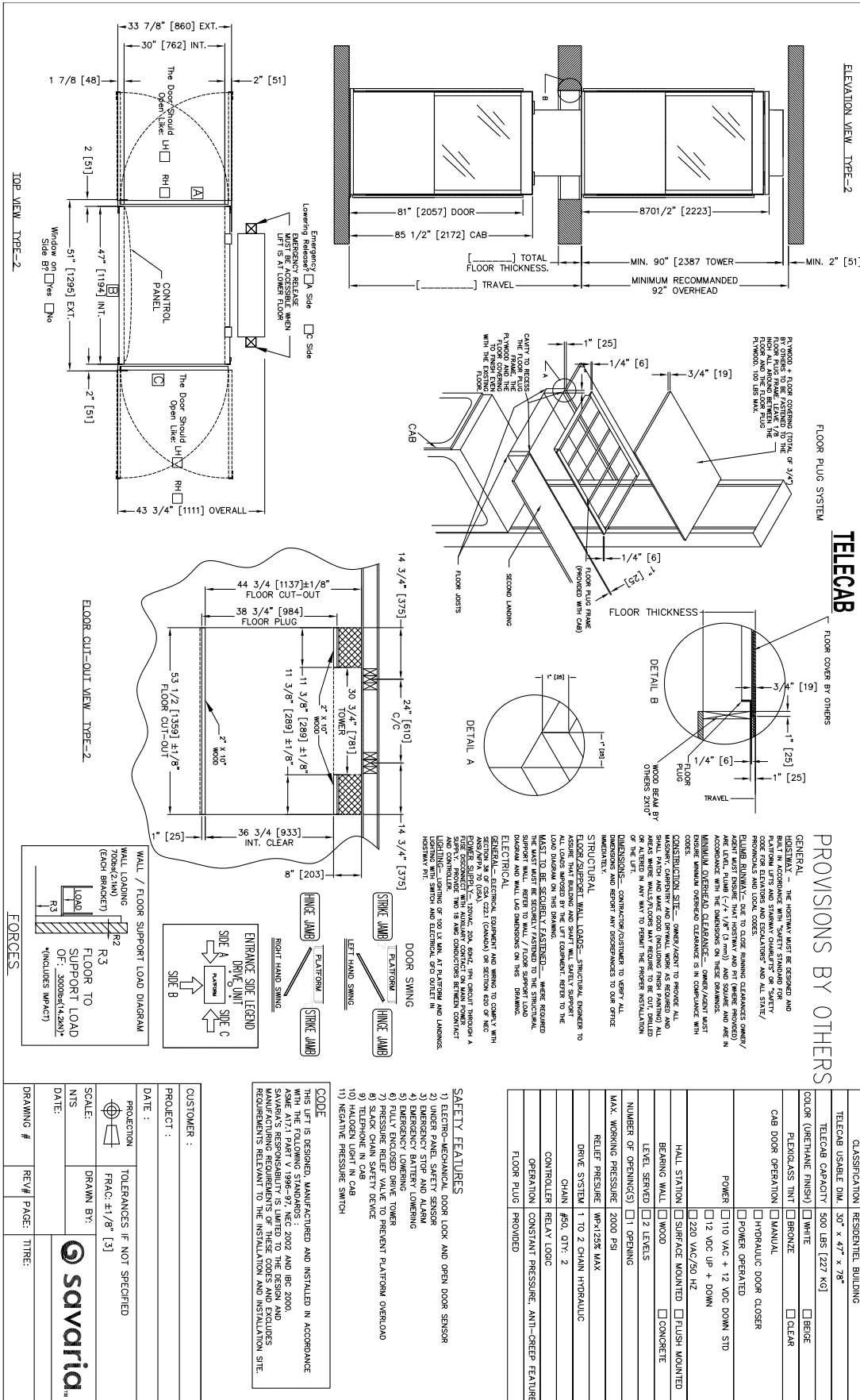
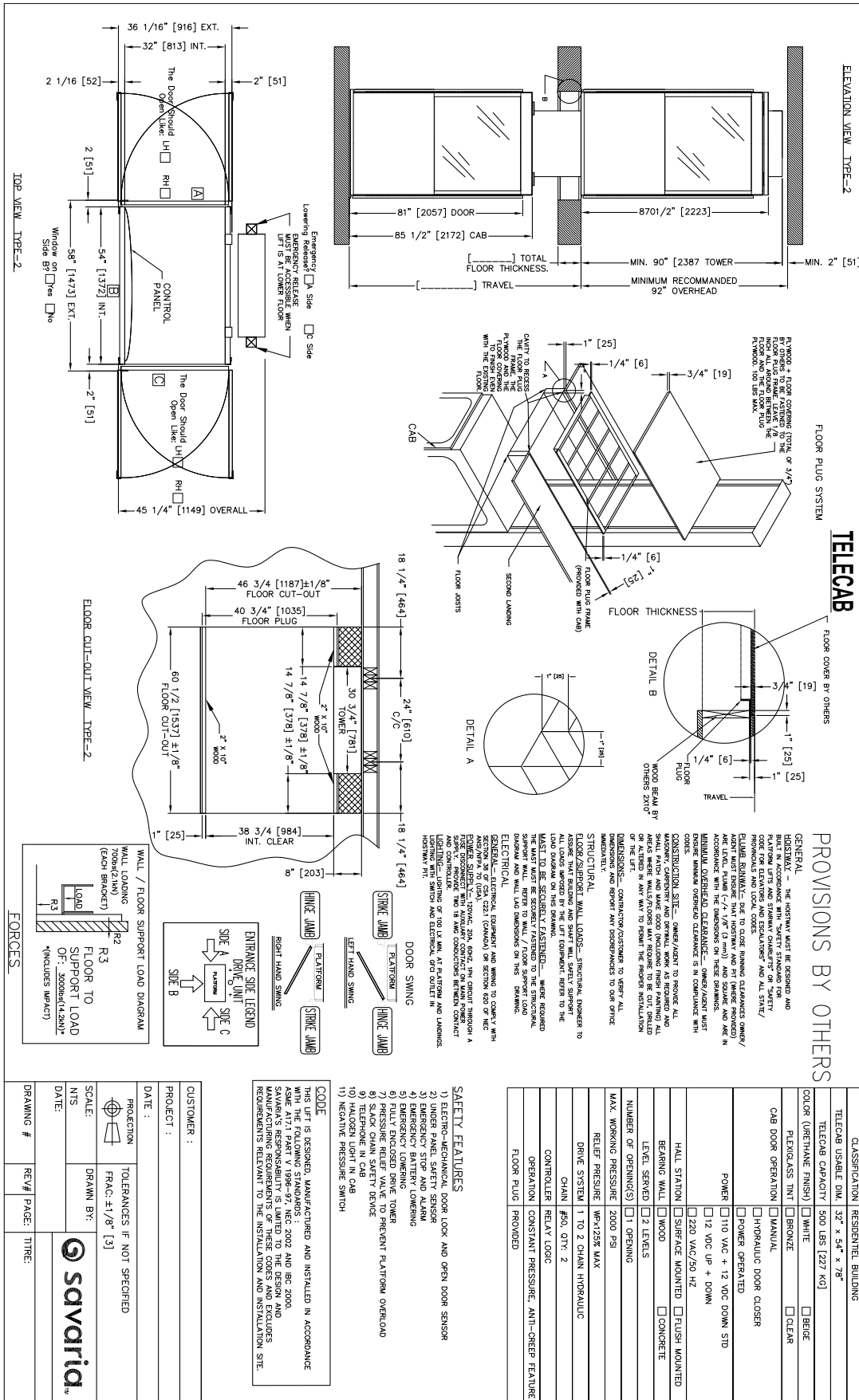

Figure 12: Type 2 – 32" x 54", left/right access



Telecab Residential Elevator PLANNING GUIDE

Part No. 000698
Copyright © 2015

Savaria Corporation
Elevators and Lifts
www.savaria.com

Support
2 Walker Drive
Brampton, Ontario, L6T 5E1, Canada
Toll free: (800) 791-7999
Fax: (905) 791-2222

