

Specification Guide Model 32

Models: 32, 32H, 32HX with 15-ft. Corded Remote Control
Models: 32W, 32WH, 32WHX with Wireless Remote Control

The Versa Lift electric storage lift is designed to move cargo between adjacent floors. The lift's power head mounts over an opening in the upper floor. When ascending, the lifting platform automatically stops level with the upper floor. When descending, the lifting platform automatically stops upon contacting the lower floor. The remote control switch operation is momentary and the motor brake is applied instantly whenever the switch is released. The platform assembly includes a spring biased door panel that automatically covers the underside of the opening whenever the platform is fully raised. This door is self-adjusting for joists up to 18" in height and can easily be sealed with common weatherstripping.

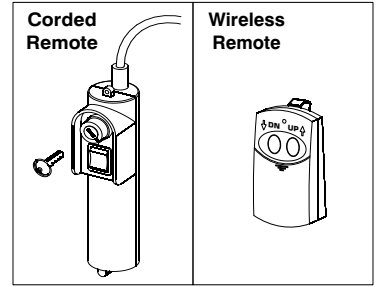

Installation Requirements:

- Opening Required:** 30 1/2 x 58 1/2" (+1/2", -0")
- Opening Finish:** Smooth perpendicular sidewalls
- Electrical:** 115 vac grounded power outlet

Installation Recommendations:

The Lift's electrical outlet and the attic lighting should preferably be on a single circuit controlled by a switch outside of the attic. For corded models, the opening should be close enough to the attic ladder so the 15' remote cord will reach through the ladder opening. For lift opening dimensions, see the **Rough-In Guide** (attached). For complete detailed information and specific framing suggestions, see the **Versa Lift Installation Guide**.

Specifications:

- Corded Control:** Hand-held remote w/15' cord & keylock
- Wireless Control:** Wireless hand-held radio remote
- Floor-to-Floor:** Model 32=8-11', 32H=11-14', 32HX=14-20'
Model 32W=8-11', 32WH=11-14', 32WHX=14-20'
- Joist Height Max:** 18" (incl. decking & sheet rock)
- Lifting Capacity:** 35 Cu. Ft., 250 lbs. per load
- Platform Dimensions:** 28 3/4"W x 56"L x 52 3/4"H
- Lift Speed:** 8"/sec. (10-ft. in approx. 15 seconds)
- Cables (2):** .093 steel w/zinc plating 1,000 lb. break
- Construction:** Powder coated steel
- Motor:** .6 HP Gear motor with automatic brake
- Voltage/Power:** 115 vac, 60 hz, 4.5 amps
- Power-head Dim.:** 34W x 69L x 60H
- Opening Required:** 30 1/2 x 58 1/2" (+1/2", -0")
- Opening Finish:** Smooth perpendicular sidewalls
- Shipping Weight:** 206 lbs.

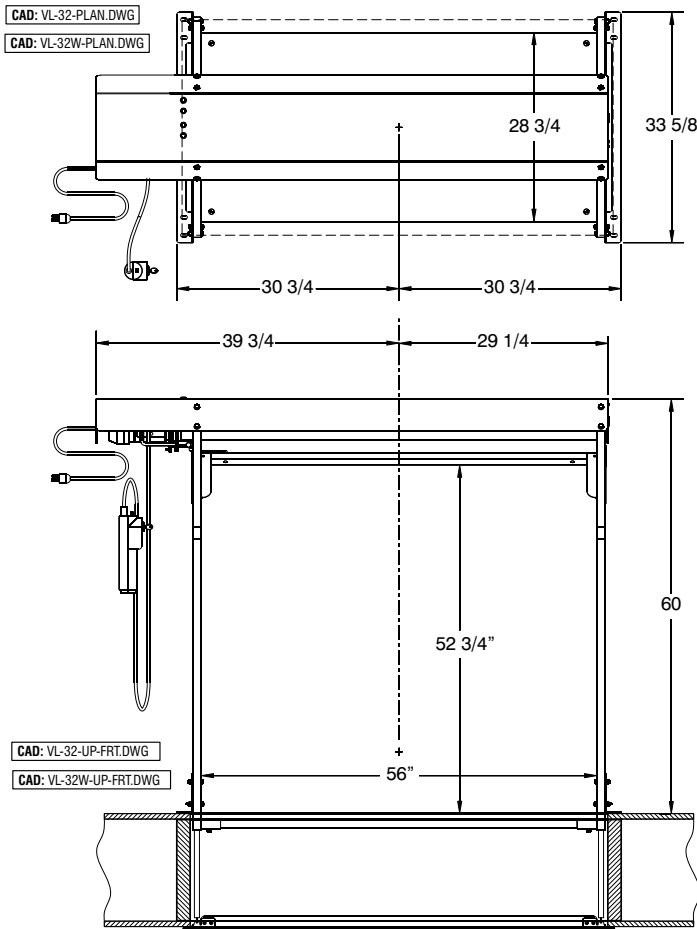

Versa Lift illustrated in the raised (UP) position.

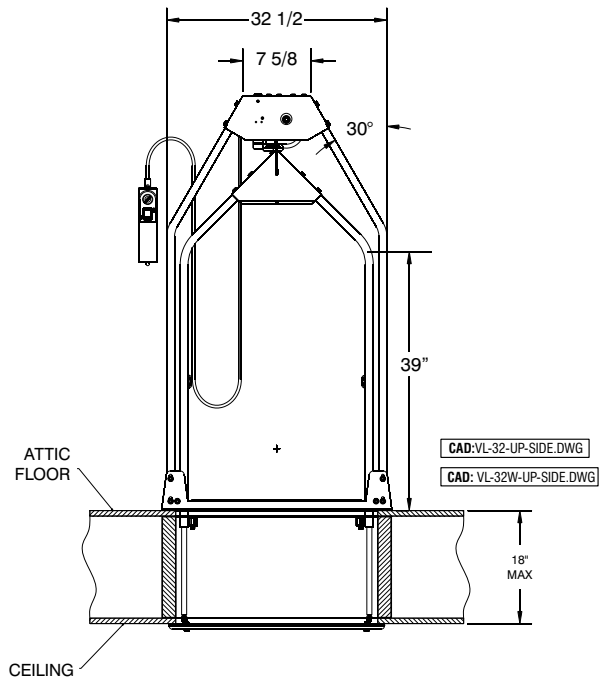

Specification Guide Model 32

Continued

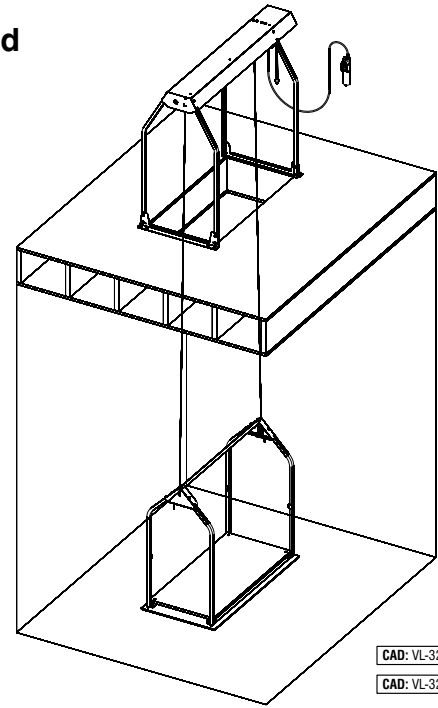
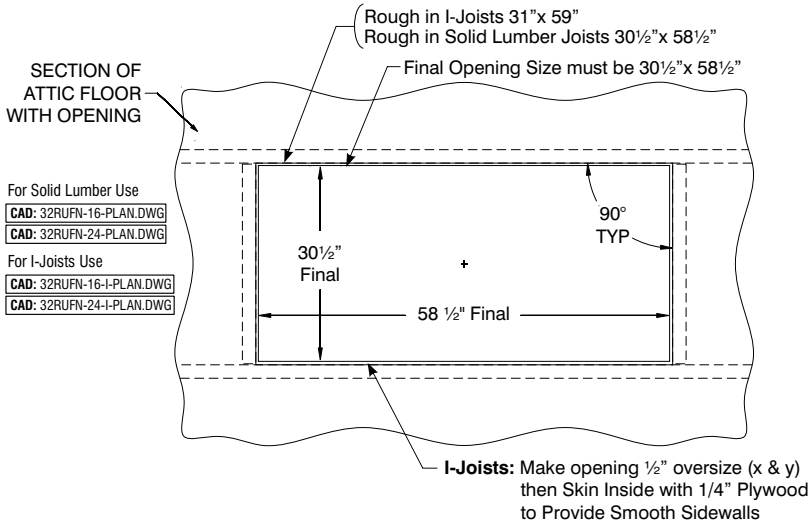

Versa Lift illustrated in the lowered (DN) position.

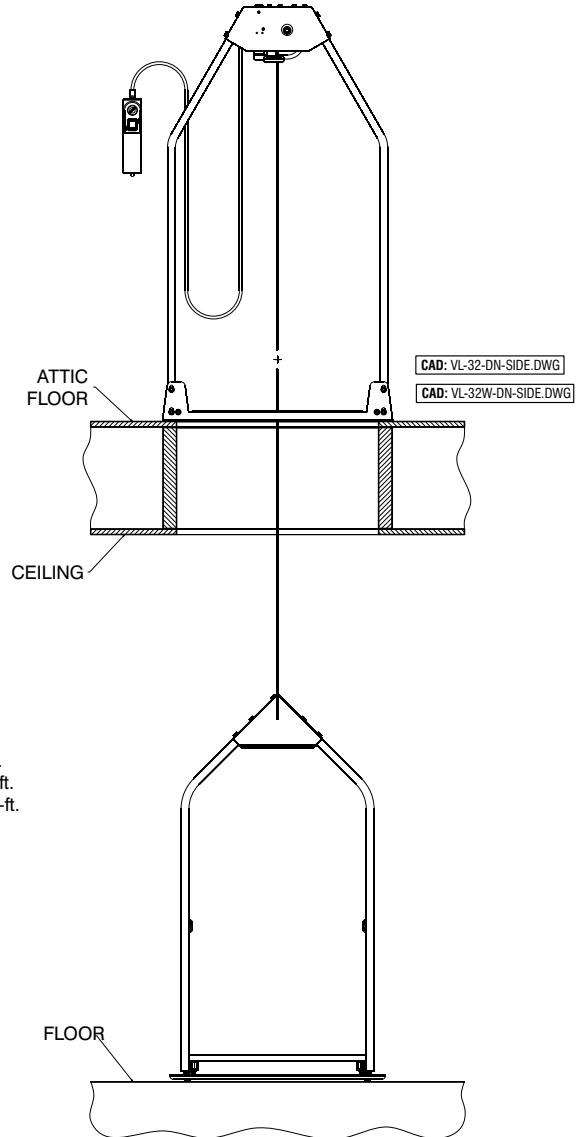
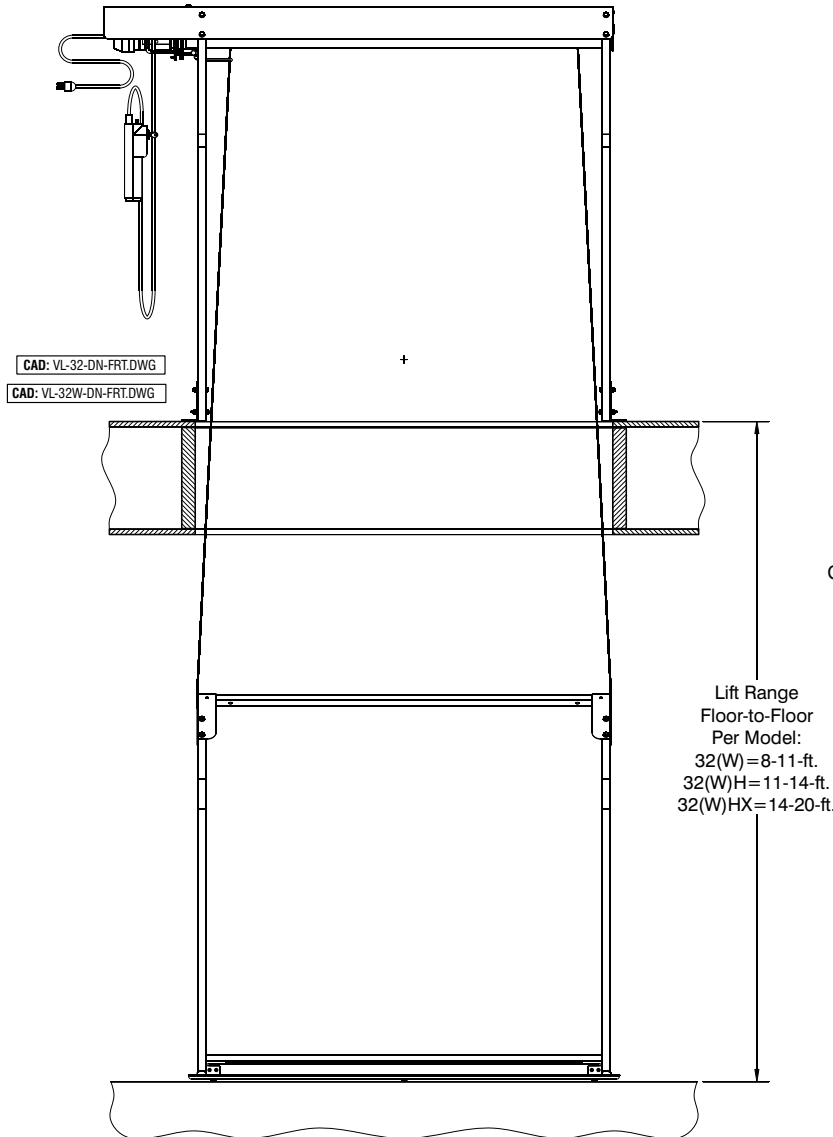

Rough-In Guide Model 32 for Solid Lumber Joists

All Models 32: (32, 32H, 32HX, 32W, 32WH, 32WHX)

Roughing-In Notes: Tolerance for opening dimensions is +1/4" (6mm) -0" (-0mm). The opening must be square and side wall perpendicular. Maximum joist height is 18" tall. See specification sheet for maximum floor-to-floor height of specific models. For detailed framing suggestions, see the Versa Lift Installation Guide.

TYPICAL FRAMING FOR 24" O.C. SOLID JOISTS

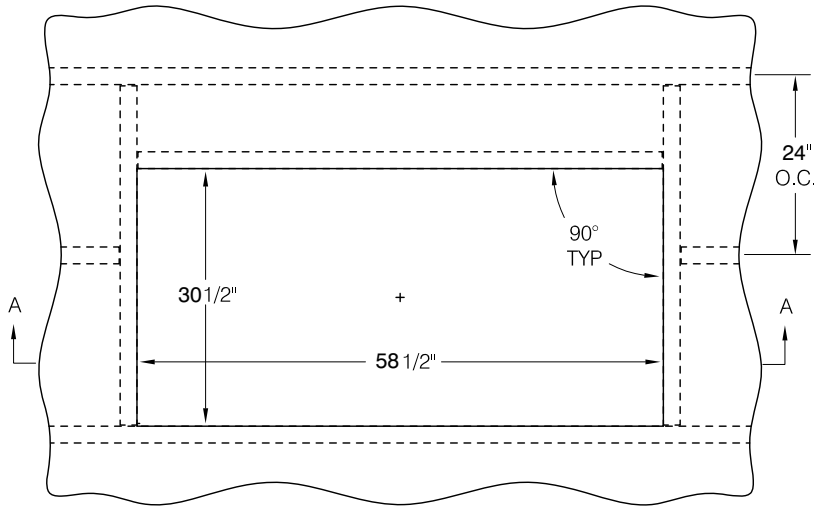

CAD: 32RUFN-24-PLAN.DWG

IMPORTANT NOTE:

The required finished opening is 30.5 x 58.5" with smooth sidewalls. Whenever joist hanger brackets are used to frame the opening, they must be covered to prevent interference with the lifting platform operation. 2 x 2" "L" shaped flashing strips (4) are provided by BPG to cover hanger brackets and nail head in the corners of the lift opening.

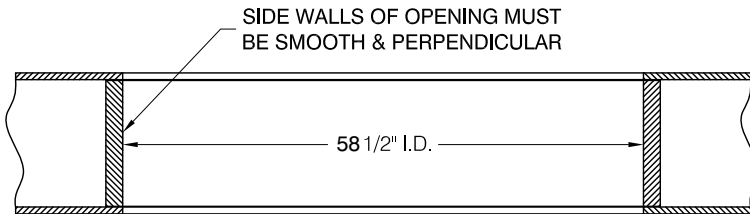

CAD: 32RUFN-FRT-X.DWG

SEC. A-A

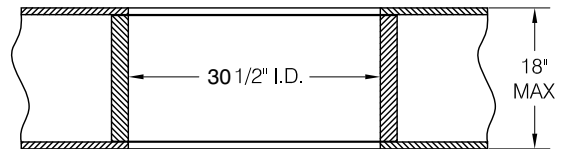

CAD: 32RUFN-SIDE-X.DWG

SEC. B-B

TYPICAL FRAMING FOR 16" O.C. SOLID JOISTS

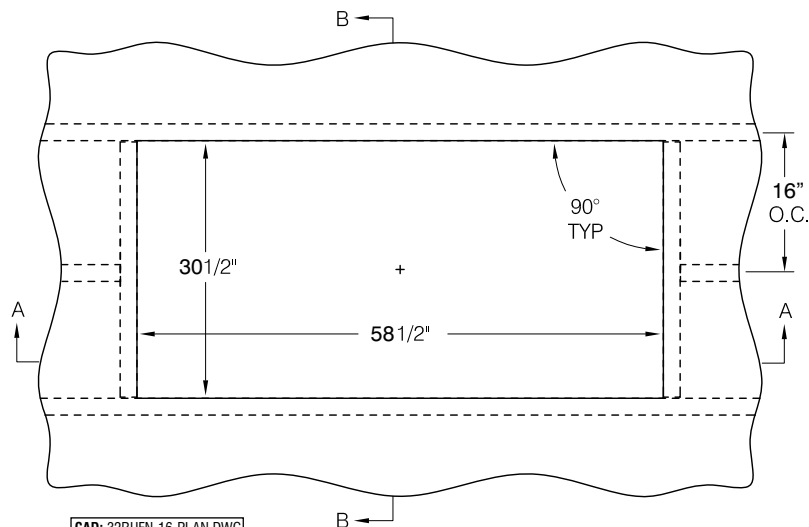

CAD: 32RUFN-16-PLAN.DWG

IMPORTANT NOTE:

The required finished opening is 30.5 x 58.5" with smooth sidewalls. Whenever joist hanger brackets are used to frame the opening, they must be covered to prevent interference with the lifting platform operation. 2 x 2" "L" shaped flashing strips (4) are provided by BPG to cover hanger brackets and nail head in the corners of the lift opening.

Rough-In Guide Model 32

for Fabricated "I-Joists"

Revised
8-5-2010

Patent
Pending

Versa Lift ™
Attic Storage Lifting System

All Models 32: (32, 32H, 32HX, 32W, 32WH, 32WHX)

Roughing-In Notes: For I-Joists, frame the opening 1/2" larger in each dimension, then skin the side walls with 1/4" plywood for a smooth opening. Tolerance for opening dimensions is +1/4" (6mm) -0" (-0mm). The opening must be square and side wall perpendicular. Maximum joist height is 18" tall. See specification sheet for maximum floor-to-floor height of specific models. For detailed framing suggestions, see the Versa Lift Installation Guide.

TYPICAL FRAMING FOR 24" O.C. Fabricated I-JOISTS

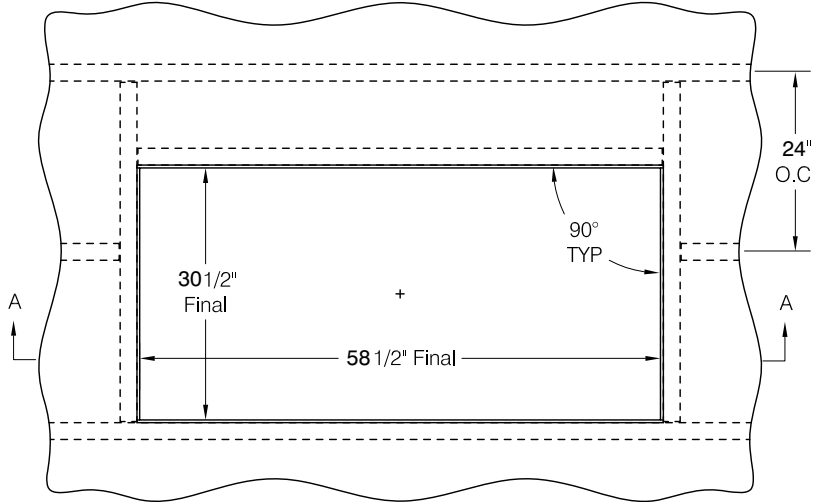

CAD: 32RUFN-16-I-PLAN1.DWG

-OR-

CAD: 32RUFN-16-I-PLAN2.DWG

Note: For I-Joists, frame opening 31" x 59", then skin inside with 1/4" plywood to make the final opening size 30.5" x 58.5" with smooth side walls.

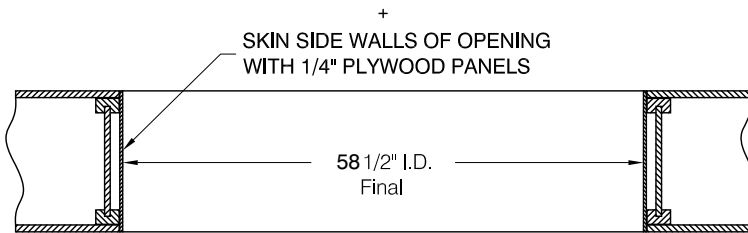

CAD: 32RUFN-I-FRT-X.DWG

SEC. A-A

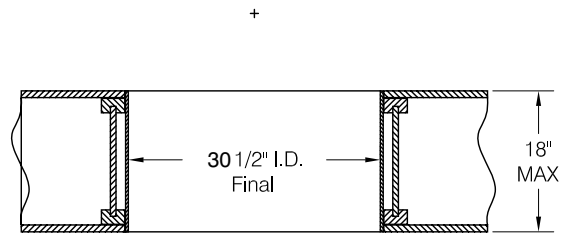

CAD: 32RUFN-I-SIDE-X.DWG

SEC. B-B

TYPICAL FRAMING FOR 16" O.C. Fabricated I-JOISTS

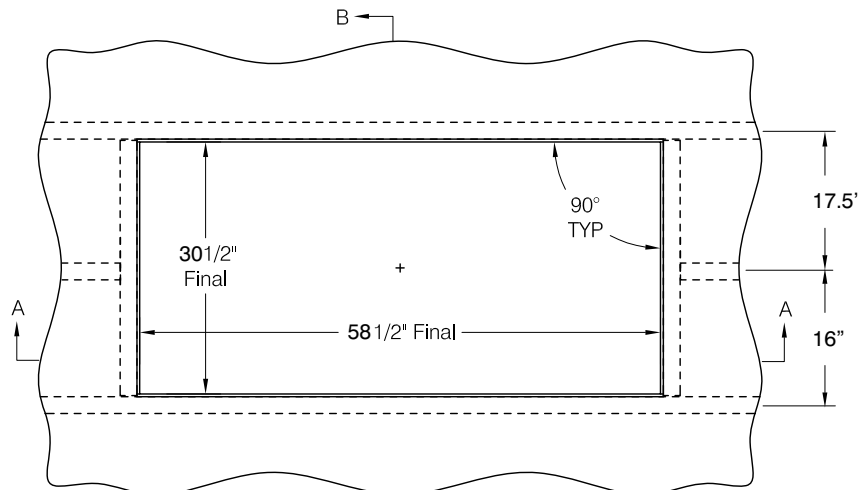

CAD: 32RUFN-24-I-PLAN.DWG

Note: For I-Joists, frame opening 31" x 59", then skin inside with 1/4" plywood to make the final opening size 30.5" x 58.5" with smooth side walls.

Important: To get the required 31" x 59" opening, one I-Joist must be shifted 1 1/2" off-center - or - you must cut two I-Joists and box in the opening using a stringer.