



Planning Guide

Residential Winding Drum Elevators

Built on J Rail

**Series 115 - Paca-Glide
Series 118 - Paca-Lift**

Waupaca Elevator’s Mission Statement

Our mission is to deliver and support an enhanced quality of life for people with a need, or want, for vertical transportation. We are dedicated to our relationships, products, and industry through teamwork and education.

Members Of:

Waupaca Elevator Company, Inc, Elevator is a proud member of The American Society of Mechanical Engineers, The National Association Elevators Contractors, The Canadian Elevator Contractor Association, The Accessibility Equipment Manufacturers Association. These symbols assures you of our commitment to high quality and accessibility to everyone.



Table of Contents

Introduction & Planning Steps.....	4
Design Features Mechanical Illustrations (Series 115).....	5
Design Features Mechanical Illustrations (Series 118).....	6
Rail and Pit Reactions	7
Elevator Equipment.....	8
Hoistway Specifications.....	9
Machine Space, Controller Install Wiring (Series 115).....	10-11
Machine Space, Controller Install Wiring (Series 118).....	12-13
Example Hoistway Construction	14
Hoistway Elevation View (Series 115).....	15
Hoistway Elevation View (Series 118).....	16
Example Hoistway Layouts.....	17-20
Notes.....	21

Introduction

This Planning Guide is to be used as a reference to determine parameters of installation and steps taken to achieve a proper elevator installation. This guide may be used by the architect, contractor, dealer or home owner. The information in this guide is intended as an overview. Each installation will have job specific specifications that must be followed. Do not attempt to construct a hoistway on this information.

Elevator installation is to be done by an authorized elevator contractor and in accordance with installation instructions provided by the manufacturer. Installation must also be in compliance with requirements of the National Electrical Code, American Society of Mechanical Engineers Safety Code, and state and local building codes. Waupaca Elevators products are designed to meet the residential elevator requirements of ASME A17.1 Safety Code for Elevators and Escalators. The manufacturer assumes no liability for equipment not installed in compliance with these codes.

Waupaca Elevator Company, Inc., reserves the right to modify the design, technical specifications and dimensions of the products shown in this document.

Planning Steps

Locate a local dealer and custom design your elevator together. Congratulations on choosing a Winding Drum drive system. If you prefer a hydraulic power based elevator please locate and use the Planning Guide for Residential Hydraulic Elevators. Please complete steps below to finish creating your elevator package.

1. Select rail system.
2. Layout machine room and location.
3. Plan for electrical requirements.
4. Address national, state, and local code requirements.
5. Determine hoistway size, car size, layout configuration, and available options. Please reference a Waupaca Elevator Brochure for available design options: cab style, car operating panels, hall stations, phone boxes, handrails, light fixtures, and gates.
6. Obtain and follow site specific field drawings. Forward all necessary documents to contractor/builder, architect, and structural engineers. Use job specific drawings while building hoistway, doorways, machine room, and any other construction related to the elevator.
7. Coordinate with your dealer to install elevator and enjoy you custom designed elevator.

Design Features & Mechanical Illustrations

J-Rail System with Winding Drum Technology (Series 115)

- (MRL) Machine Roomless
- Modular Design Built on J Rail System
- Utilizes Proven Winding Drum Technology
- System Free of Hydraulic Oil
- Durable Cantilever Sling Design
- Sling Movement Translates Through Gliding Blocks
- PLC Control System with Variable Frequency Drive
- Tape Reader Locates Floors with Magnetic Sensor
- Emergency Hand Wheel is Standard
- Access Door Required by Powerhead Hand Wheel
- Battery Lowering Back Up System is Standard

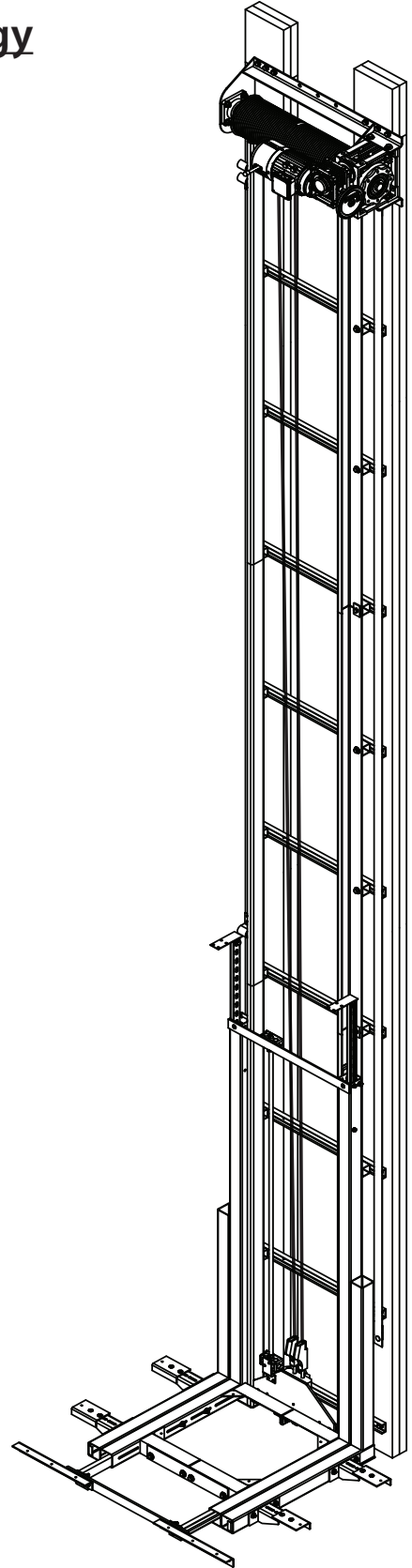
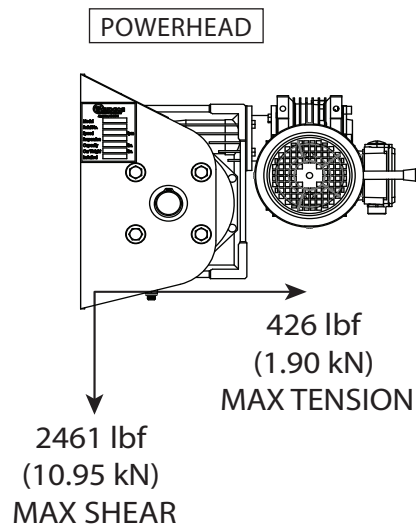

Design Features & Mechanical Illustrations

J-Rail System with Winding Drum Technology

(Series 118)

- Multiple Machine Room Layouts
- Modular Design Built on J Rail System
- Utilizes Proven Winding Drum Technology
- System Free of Hydraulic Oil
- Durable Cantilever Sling Design
- Sling Movement Translates Through Gliding Blocks
- PLC Control System with Variable Frequency Drive
- Tape Reader Locates Floors with Magnetic Sensor
- Emergency Hand Wheel is Standard
- Battery Lowering Back Up System is Standard

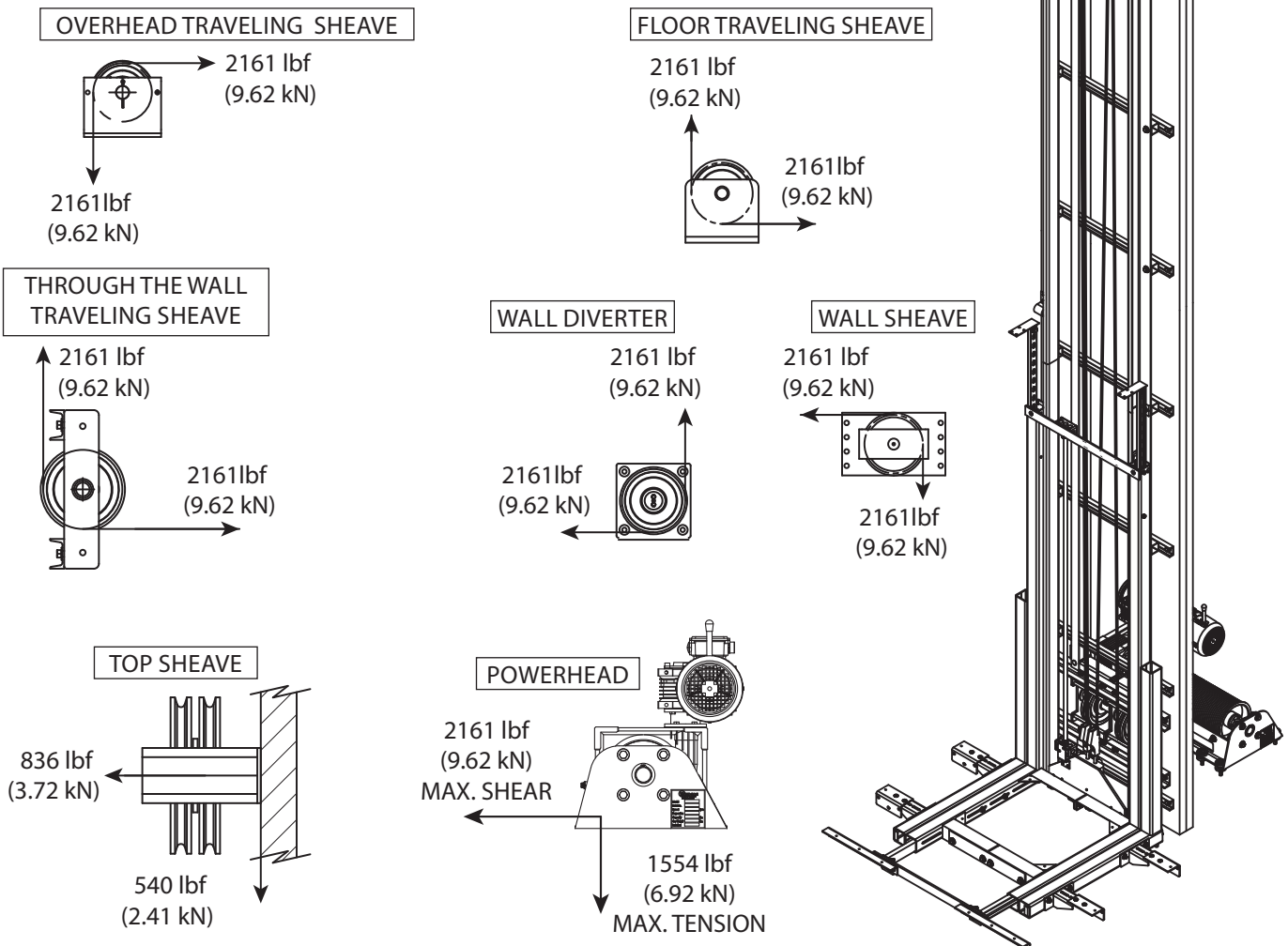

MAXIMUM LIVE (STATIC) LOAD = 1000 lbf
MAXIMUM DEAD (STATIC) LOAD = 1161 lbf (SEE NOTE #3)
MAXIMUM TOTAL (STATIC) LOAD = 2161 lbf
MAXIMUM SHEAR (STATIC) PER BRACKET = 534 lbf (267 lbf PER FASTENER)
MAXIMUM TENSION (STATIC) PER BRACKET = 836 lbf (418 lbf PER FASTENER)

SIDE VIEW OF RAIL BRACKET

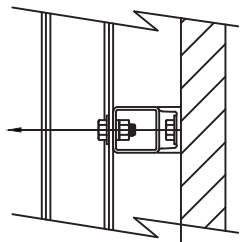

836 lbf (3.72 kN)
MAX TENSION

540 lbf (2.41 kN)
MAX SHEAR

NOTES:

1. FASTENERS BY OTHERS.
2. FILL ALL ANCHOR POINTS.
3. DEAD LOAD OF ELEVATOR INCLUDES SLING, CAB, FLOORING GATE(S), ETC. AND ALL PERMANENT FIXTURES.
4. IT IS THE RESPONSIBILITY OF THE INSTALLER/CONTRACTOR OR ENGINEER TO DESIGN AND SPECIFY STRUCTURAL SUPPORTS.
5. ALL CONSTRUCTION TO BE IN COMPLIANCE WITH LOCAL CODES.
6. MAXIMUM RAIL BRACKET TENSION/SHEAR MOVES UP AND DOWN SUPPORT WALL AT 40 FEET PER MINUTE.
7. GUIDE RAIL SUPPORT WALL CANNOT EXCEED 1/8" OF TOTAL DEFLECTION AT POINT OF SUPPORT. (PER ASME A17.1 2.23.5.2)

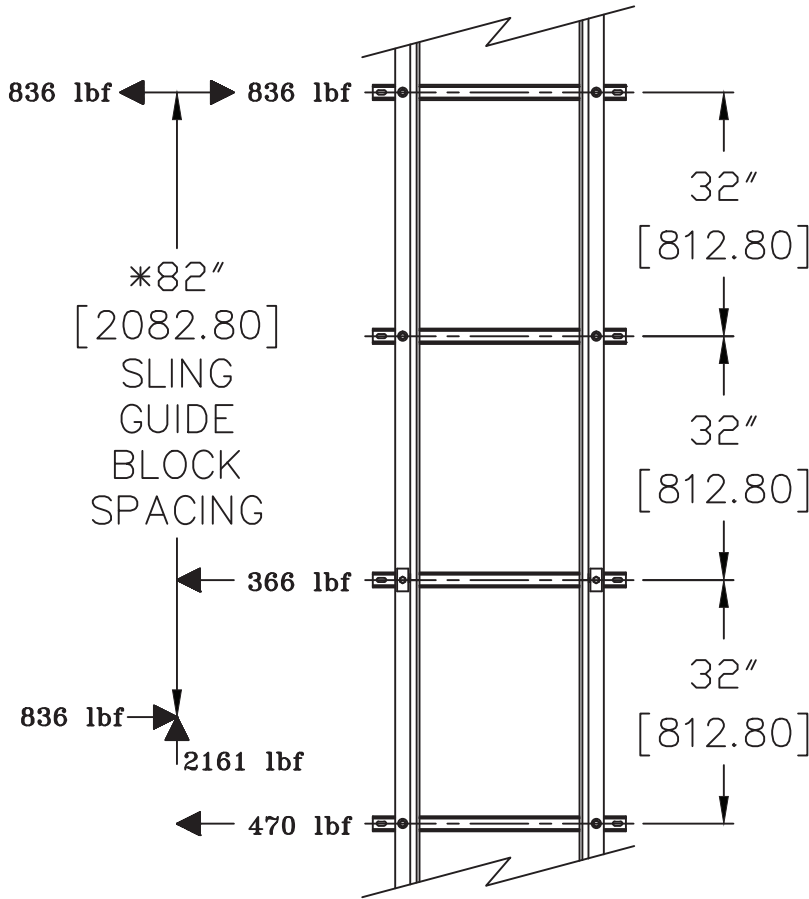

NOTE:
ALL DIMENSIONS ARE IN INCHES.
DIMENSIONS IN [] ARE MM.

RAIL BRACKET

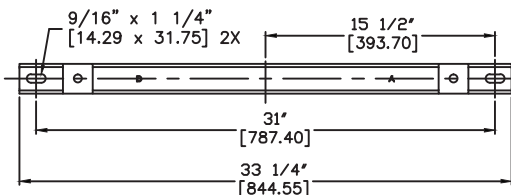

TOP VIEW OF RAIL (115 & 118)

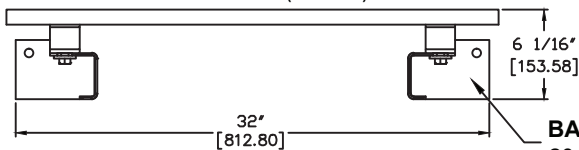

BASE PLATE
20.375 in²

TOP VIEW OF PEDESTAL BASE (116)

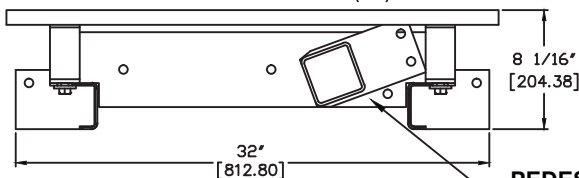

PEDESTAL BASE
114 in²

(BUFFER SPRINGS ARE PROVIDED WHEN PIT DEPTH IS 15" OR GREATER)
BUFFER SPRING LOCATION

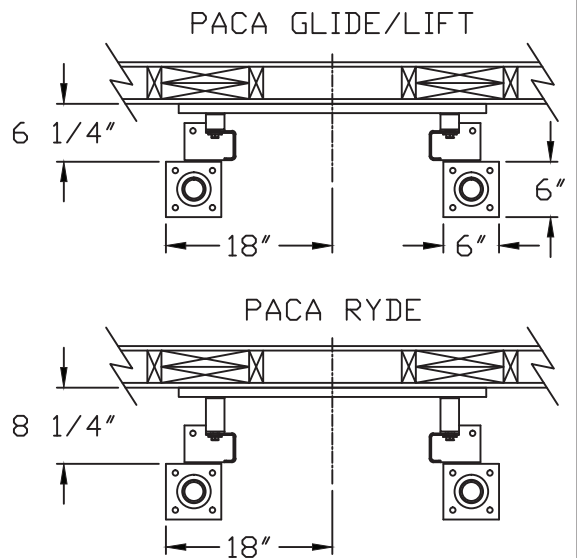

Impact Load Per Spring (Per ASME A17.1 8.2.3.2)

1/2 Weight of Dead and Live Load	1080.5 lbs
Maximum Stroke of Buffer Spring	2.71 in
	0.226 ft
Impact	2264 lbs



1726 North Ballard Road
Appleton, WI 54911
Phone: 800-238-8739

ELEVATOR CONTRACTOR:

JOB NAME:

ORDER NUMBER:

**PACA-SERIES
RAIL AND PIT FLOOR REACTIONS**

DRAWN BY:

DATE:

SIGNATURE OF APPROVAL

DWG. NO.

C-003070

Elevator Equipment - Series 115 & 118

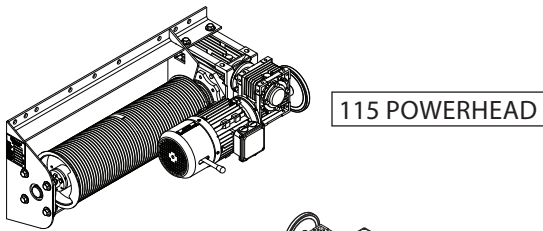

Powerhead
The powerhead is a motor and gearbox that efficiently moves the elevator car by a positive means of wrapping a steel wire rope around a grooved drum.

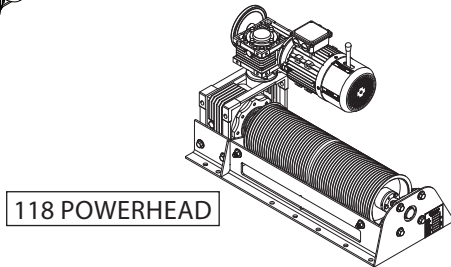

Gearbox
Double reduction sealed gearbox combination for greater efficiency and reduced maintenance.

Motor
230V 3-phase brake motor for efficiency, higher torque, speed control, and landing accuracy.

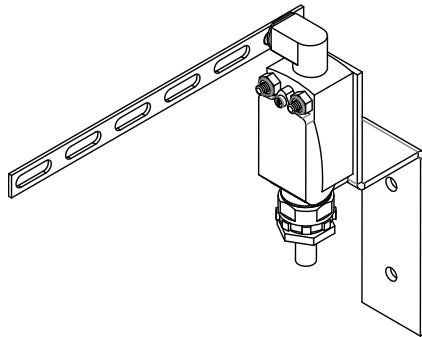
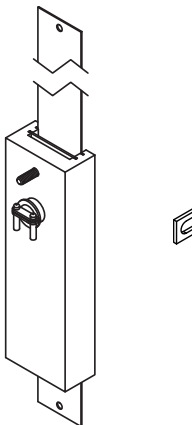

Stopping Devices
Magnetic tape reader for landing accuracy & final limit switches.

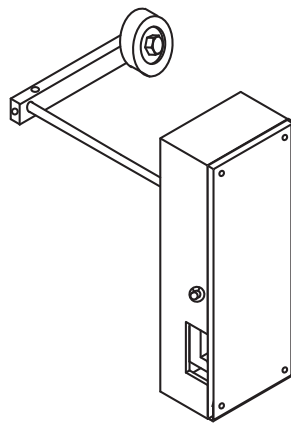
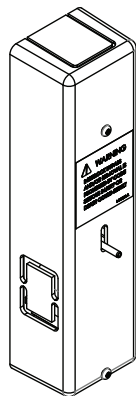

Hoistway door interlocks
EMI or GAL Type "N"
To prevent the opening of the hoistway door from landing side unless the car is within landing zone or stopped at landing.

Hoistway Specifications - Series 115 & 118

ATTENTION CONSTRUCTION CONTRACTOR:

Job specific documentation for hoistway construction from Waupaca Elevator will be provided to your local dealer.

Hoistway Construction Requirements to be completed prior to elevator installation by contractor.

1. Electrical Requirements By Others:

- Dedicated 230 VAC 35 AMP Circuit Single Phase with ground and neutral, 60 Hertz.
- A fused disconnect switch with branch 3 pole circuit wire to suit a 30 AMP service, fused for 30 AMP dual element (time delay fuse) with neutral.
- Dedicated 115 Volt, 15 AMP single phase circuit for car lighting.
- Electrical wiring to comply with applicable codes.
- Any VAC other than 230 VAC may require a buck/boost transformer.

NOTE :

Electrical requirements are for general reference only. All job specific electrical requirements must be acquired from job specific drawings provided by Waupaca Elevator Company, Inc.

- Unfinished/Un-installed Door** - Installation company may prefer a minimum of one hoistway door and associated framing be left unfinished/un-installed to accommodate elevator installation equipment and to prevent accidental damage to door and framing (preferably at grade level).
- Plumb and Square Hoistway** - Hoistway must be plumb within 1/8 inch per 10 feet of height and square at any point within 1/4 inch based on difference in diagonal measurements.
- Supportive Structure** - Structure must be capable of supporting the appropriate loads. Local engineering support is recommended.
- Telephone Connection** - Code requires a telephone connection to the elevator car; therefore, a phone line must be installed leading to the controller.
- ASME A17.1 Section 5.3** - Hoistway to be constructed in accordance with ASME A17.1 section 5.3 and all local codes.
- Hoistway Door Security (Interlocks)** - All hoistway doors require interlocks as well as a door handle and a latch set. Interlocks will be installed by the elevator installers. Waupaca Elevator requires the use of solid core doors and recommends spring door hinges.
- Hoistway Requirements** - Any operating equipment must meet National Electrical Code and all local codes. Machine space must have a dedicated convenience outlet and light with switch. Temperature must be maintainable between 60° - 110° F and must not be exposed to the elements (with a relative humidity not to exceed 95%).
- No Alterations** - Any alterations to the equipment without written authorization by Waupaca Elevator will void all warranties.
- Pit Floor Strength** - A pit floor must be designed to withstand a load of 4,000 lbs. When used, concrete must be a minimum of 4" thick and rated at 3500 PSI.
- Rated Load** - Elevator system is rated for maximum capacity from the factory. Flooring, walls, trim, base, and/or permanent decor added to elevator car must be subtracted from car capacity.
- Verify Code Requirements** - Verify national, state, and local code requirements are all met before installation.

Machine Space, Controller Install & Wiring

(Series 115)

Disconnect Power Before Wiring

- Locate controller enclosure in the machine room as required by code.
- Wire gauge requirements:
 - 10 gauge wire for power and motor wiring
 - 12 gauge wire for brake
 - 18 gauge (minimum) wire for all other
- Refer to unit specific schematics and field drawings to complete wiring.
Wire per N.E.C. and local codes.

Note: Not all controller terminals or travel cable wires may be used. High voltage and low voltage wires must run separate and only cross over perpendicular to each other.

- Locate and check for correct fuse sizes.

Per NEC Code 110.26

Clear Working Space. The working space required by this section must be clear at all times. **Therefore, this space isn't permitted for storage.** When normally enclosed live parts are exposed for inspection or servicing, the working space, if in a passageway or general open space, must be suitably guarded.

Working Space. Equipment that may need examination, adjustment, servicing, or maintenance while energized must have working space provided in accordance with (1), (2), and (3):

1. Depth of Working Space. The working space, which is measured from the enclosure front, must not be less than the distance of 36".
2. Width of Working Space. The width of the working space must be a minimum of 30", but in no case less than the width of the equipment.

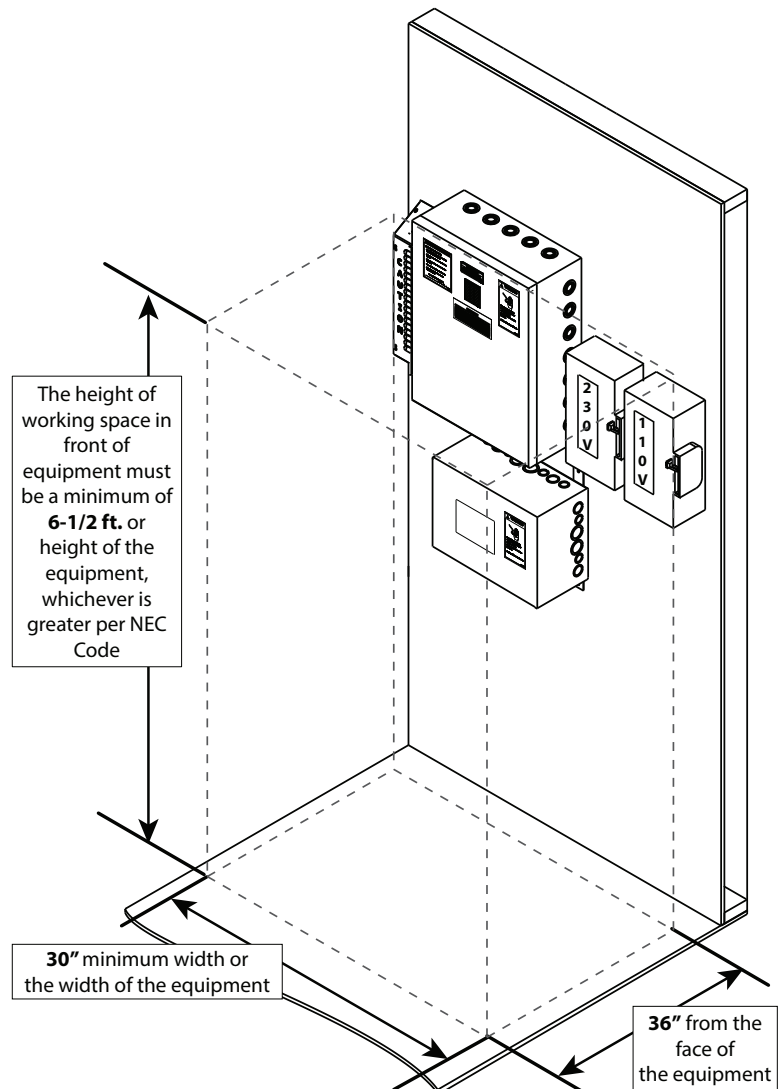

Machine Space, Controller Install & Wiring Cont.

(Series 115)

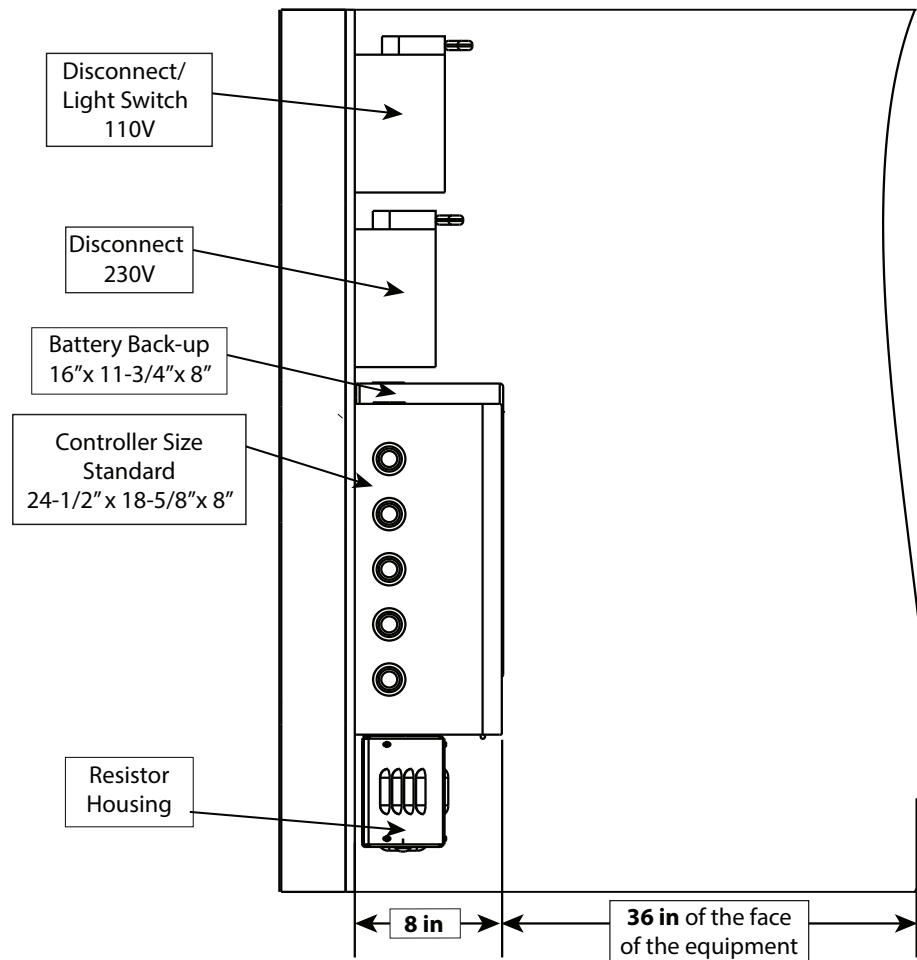

Per NEC Code 110.26 Continued

3. Height of Working Space (Headroom). The height of the working space in front of equipment must not be less than 6½' or the height of the equipment measured from the floor, grade or platform, whichever is greater.

Other equipment must not extend more than 6" into the controller working space.

Additional Notes

- A lockable service disconnect must be placed within sight of the controller and must be easily accessible in case of an emergency.
- Machine room and controller space must contain a convenience outlet and light with switch.
- The temperatures must be maintained between 60°- 110°F and must not be exposed to the elements (with a relative humidity not to exceed 95%).
- The frequency drive may be heard running for thermal heat dissipation at any time.

Machine Space, Controller Install & Wiring

(Series 118)

Disconnect Power Before Wiring

- Locate controller enclosure in the machine room as required by code.
- Wire gauge requirements:
 - 10 gauge wire for power and motor wiring
 - 12 gauge wire for brake
 - 18 gauge (minimum) wire for all other
- Refer to unit specific schematics and field drawings to complete wiring.
Wire per N.E.C. and local codes.

Note: Not all controller terminals or travel cable wires may be used. High voltage and low voltage wires must run separate and only cross over perpendicular to each other.

- Locate and check for correct fuse sizes.

Per NEC Code 110.26

Clear Working Space. The working space required by this section must be clear at all times. **Therefore, this space isn't permitted for storage.** When normally enclosed live parts are exposed for inspection or servicing, the working space, if in a passageway or general open space, must be suitably guarded.

Working Space. Equipment that may need examination, adjustment, servicing, or maintenance while energized must have working space provided in accordance with (1), (2), and (3):

1. Depth of Working Space. The working space, which is measured from the enclosure front, must not be less than the distance of 36".
2. Width of Working Space. The width of the working space must be a minimum of 30", but in no case less than the width of the equipment.

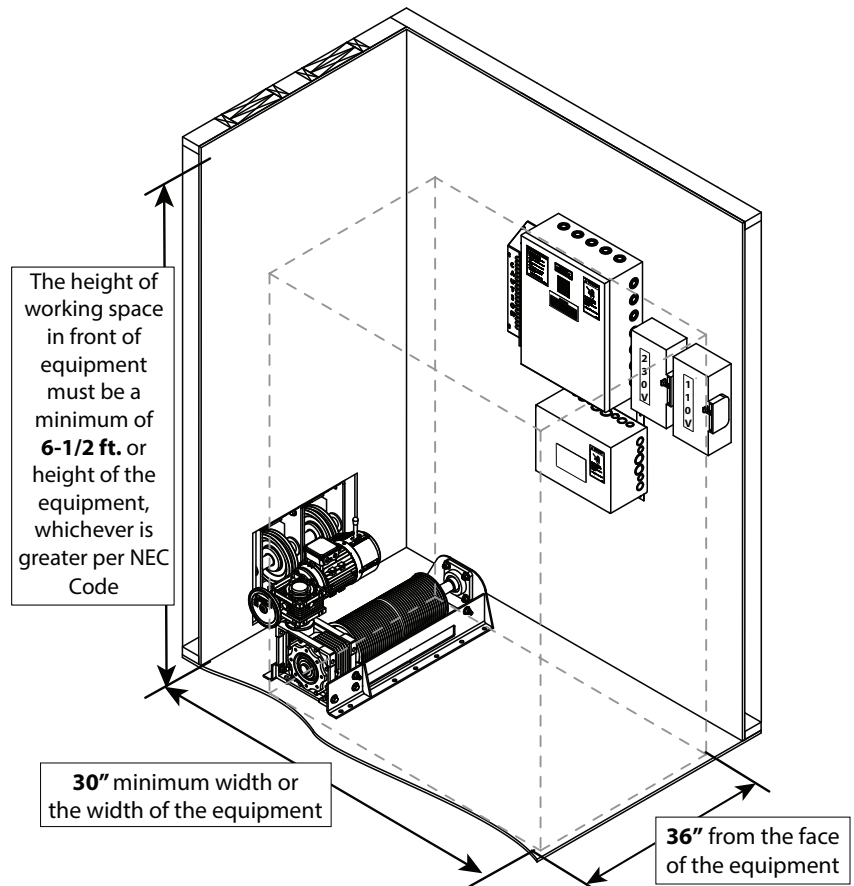

Machine Space, Controller Install & Wiring Cont.

(Series 118)

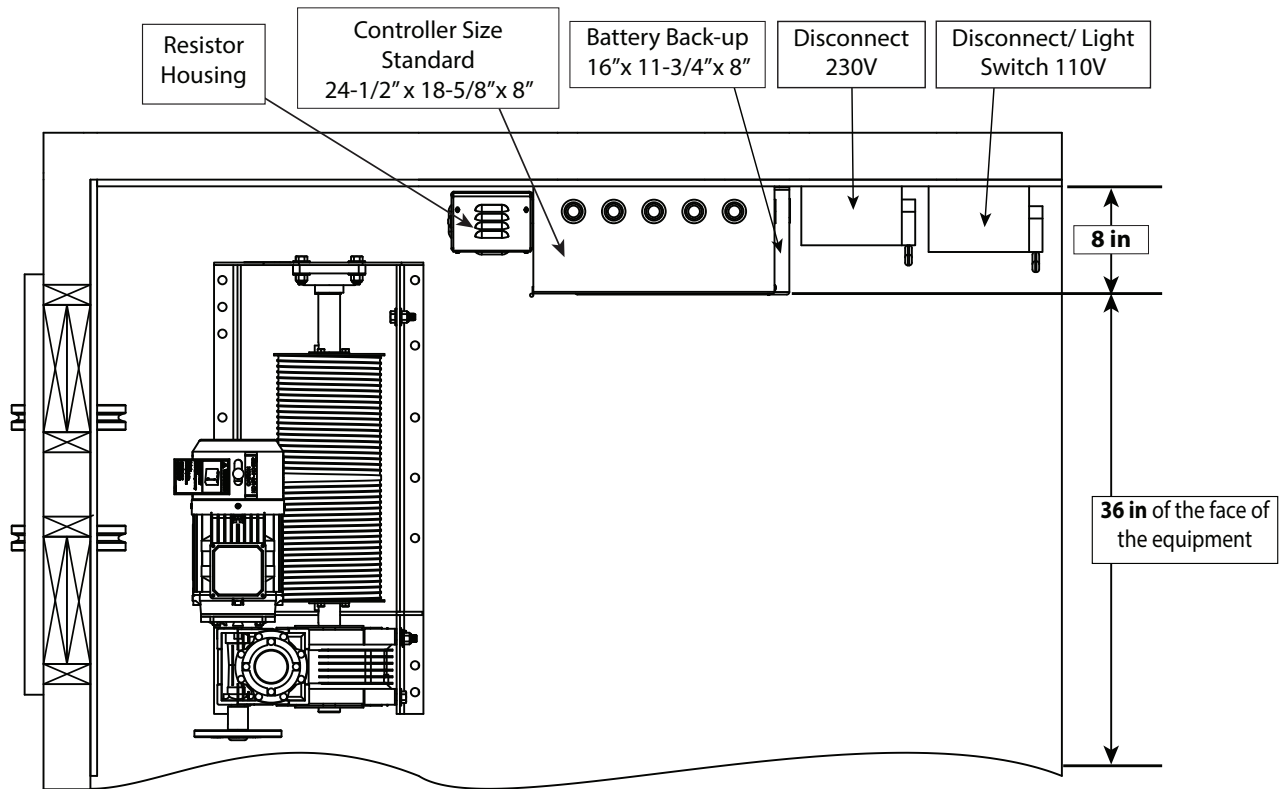

Per NEC Code 110.26 Continued

3. Height of Working Space (Headroom). The height of the working space in front of equipment must not be less than 6½' or the height of the equipment measured from the floor, grade or platform, whichever is greater.

Other equipment must not extend more than 6" into the controller working space.

Additional Notes

- A lockable service disconnect must be placed within sight of the controller and must be easily accessible in case of an emergency.
- Machine room and controller space must contain a convenience outlet and light with switch.
- The temperatures must be maintained between 60°- 110°F and must not be exposed to the elements (with a relative humidity not to exceed 95%).
- The frequency drive may be heard running for thermal heat dissipation at any time.
- Consider space for the hand wheel to be used.

Example Hoistway Construction - Series 115 & 118

Typical layouts shown here may vary from your actual hoistway.

The purpose of these layouts is for a general understanding.

Please refer to the Waupaca Elevator drawings and specifications that will be provided by your local dealer.

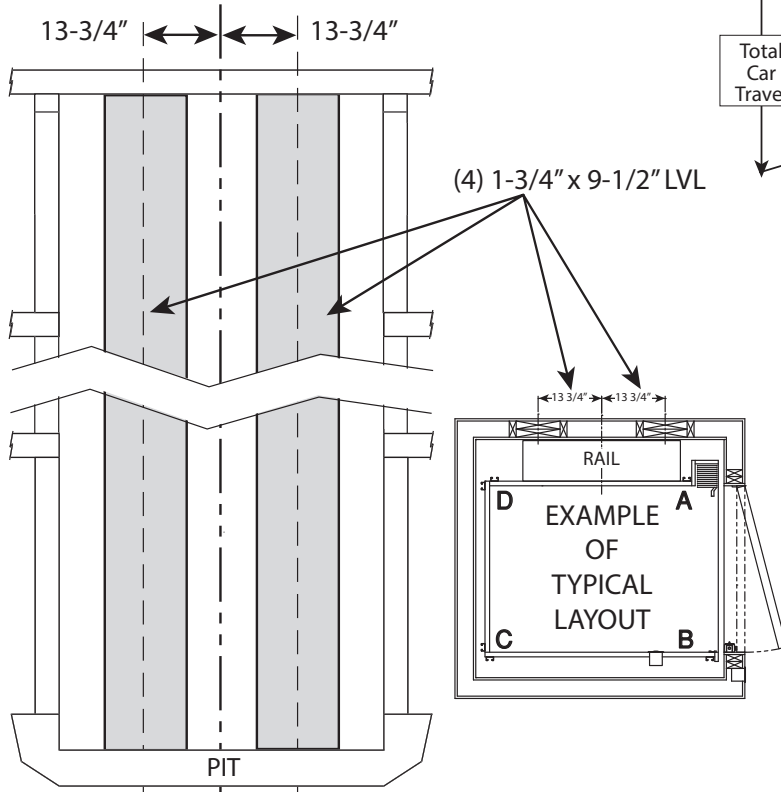
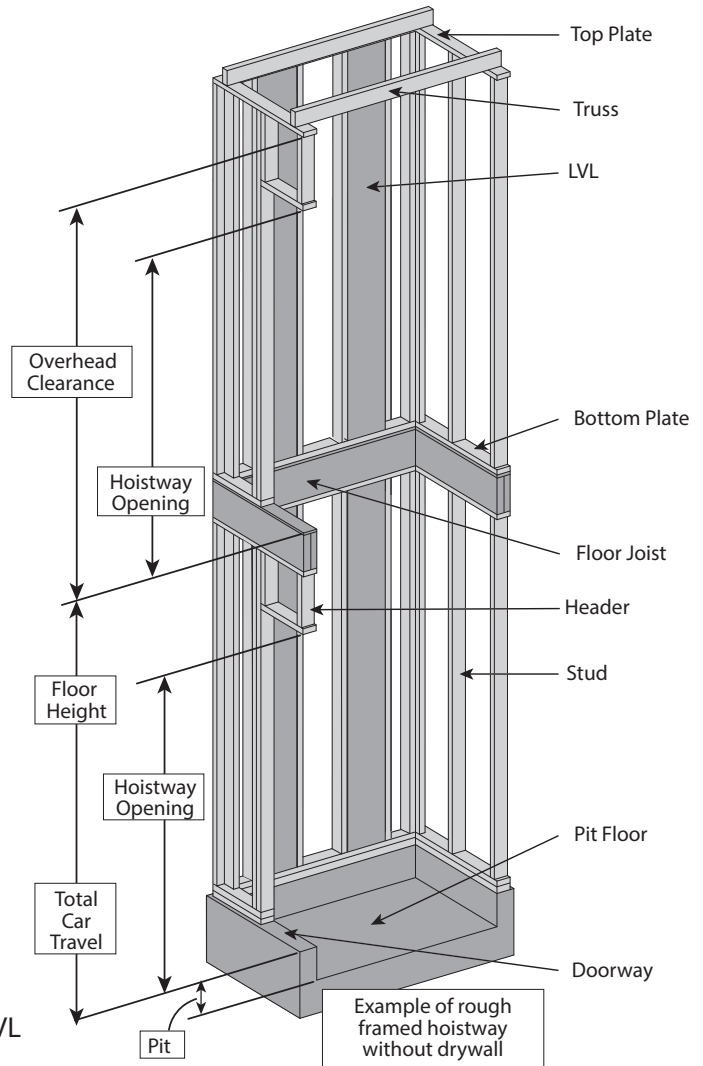

These drawings depict sample construction only. It is the responsibility of the installer/contractor or engineer to design and specify structural supports. All construction to be in compliance with local codes.

Hoistway Elevation View with J Rail - Series 115

- Structure is required to support lifting device for powerhead installation. Locate near center of shaft (by others) minimum rating for 1,000 lbs. Additional space may be required for hoisting and maneuvering equipment into place.
- Access Door is required by powerhead handwheel
- Additional disconnect required at top of elevator hoistway by motor of the powerhead per NEC Code 430.102 (B) (1).
- Waupaca Elevator's Paca Series offers a total of six stops and a total travel distance of 50 feet.

Required Overhead Heights

Inside Cab Dimension	6' 10"	7' 0"	7' 4"	8' 0"
Minimum Hoistway Overhead Height	9' 0"	9' 2"	9' 6"	10' 2"

*Custom sized cabs will alter these dimensions. Waupaca Elevator will provide you with the appropriate dimensions. Please contact your local dealer to acquire alternate layouts.

Elevation

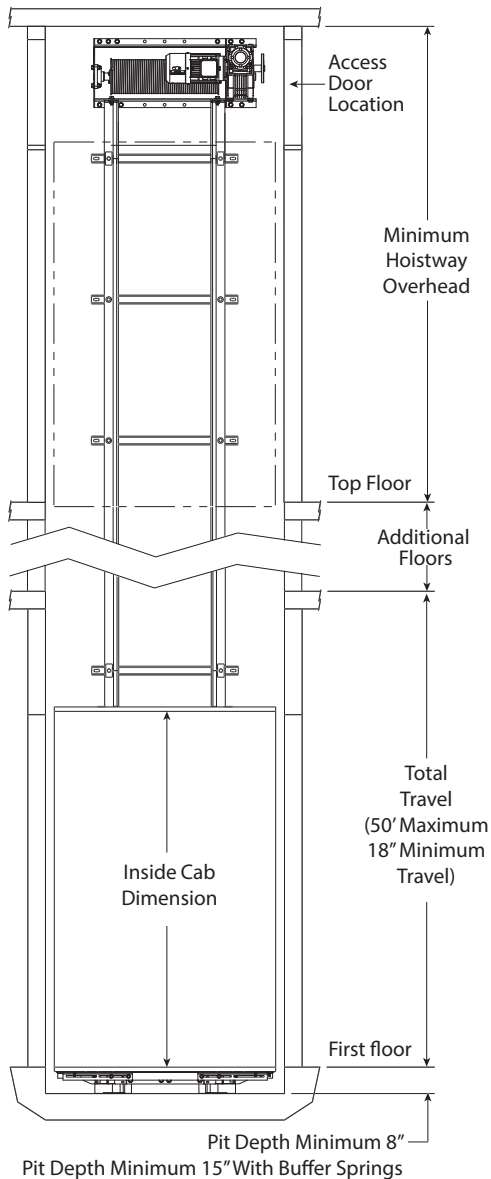

Rail Layout

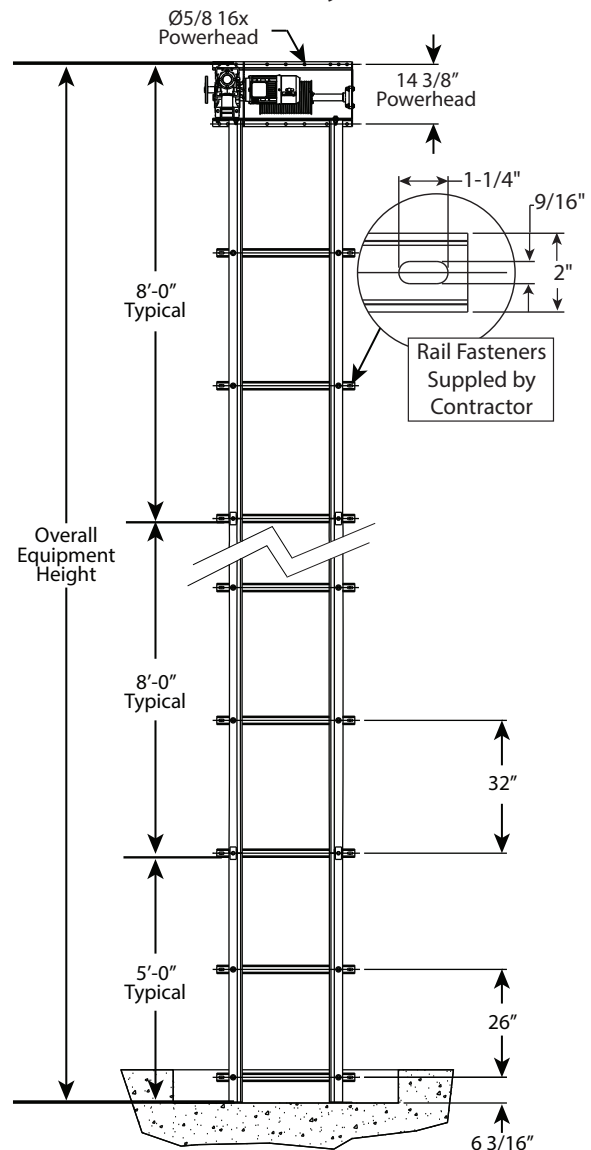

Rail Calculations

$$\text{Rail Length} = \text{Pit Depth} + \text{Travel} + \text{Car I.D. Height} + 10''$$

Hoistway Elevation View with J Rail - Series 118

Required Overhead Heights

Inside Cab Dimension	6' 10"	7' 0"	7' 4"	8' 0"
Minimum Hoistway Overhead Height	7' 10"	8' 0"	8' 4"	9' 0"

*Custom sized cabs will alter these dimensions. Waupaca Elevator will provide you with the appropriate dimensions. Please contact your local dealer to acquire alternate layouts.

Waupaca Elevator's Paca Series offers a total of six stops and a total travel distance of 50 feet.

Elevation

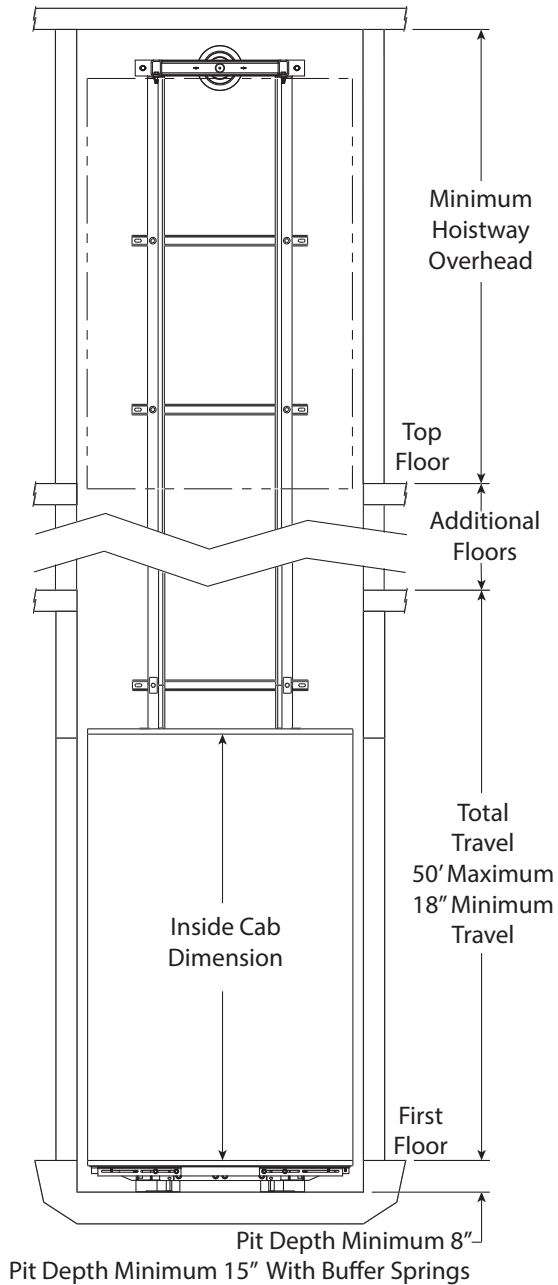

Rail Layout

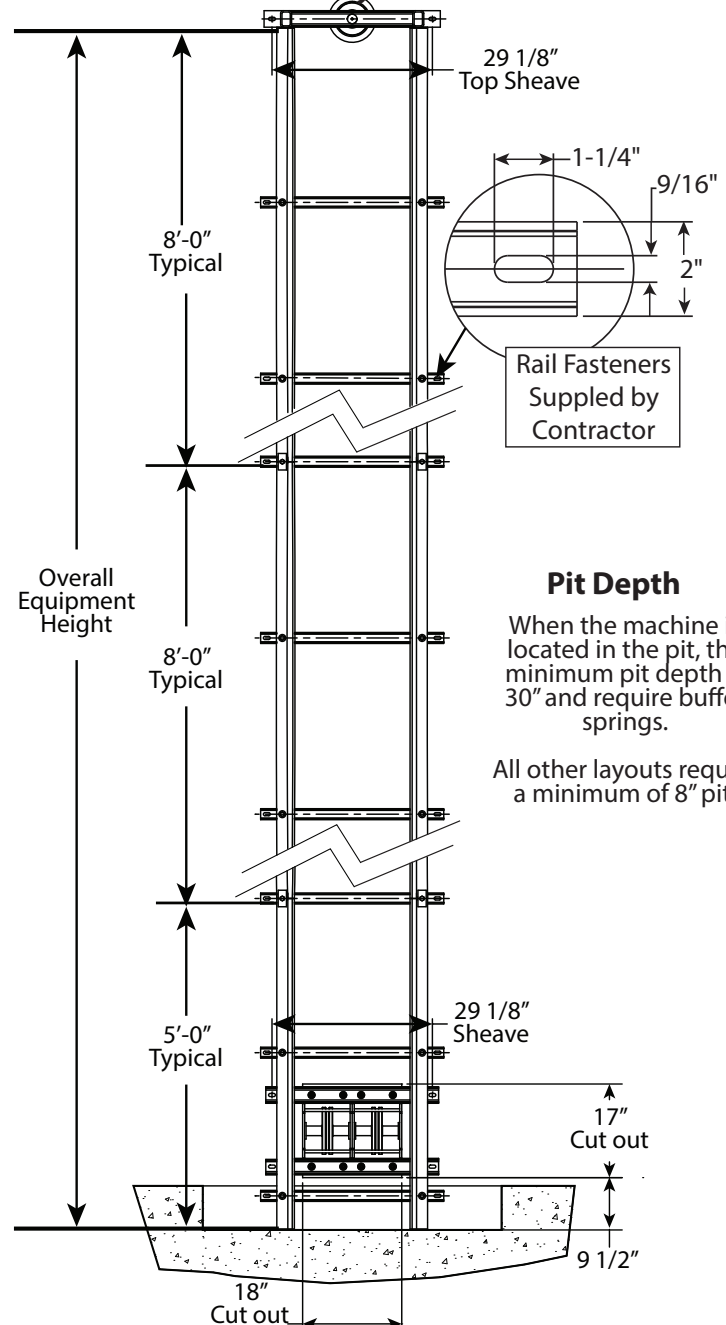

Pit Depth

When the machine is located in the pit, the minimum pit depth is 30" and require buffer springs.

All other layouts require a minimum of 8" pit.

Rail Calculations

$$\text{Rail Length} = \text{Pit Depth} + \text{Travel} + \text{Car I.D. Height} + 10''$$

Example Hoistway Layouts - Series 115 & 118

Minimum and Maximum Dimensions

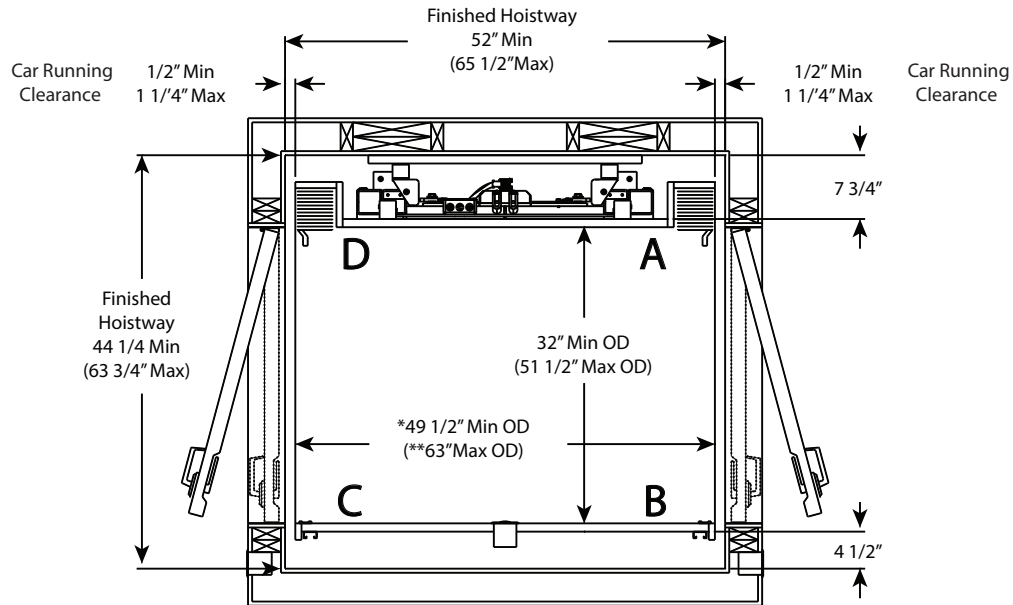

* Single Opening - 42 - 3/4" OD (Outside dimension) **minimum** (Rail is not centered in hoistway)

** Single Opening - 62 - 1/2" OD (Outside dimensions) **maximum**

Note:

1. Minimum DA dimensions reflect rail centered in hoistway.
2. Minimum DA dimension for car without a gate recess is 36" OD (outside dimension)
Car ID (inside dimensions) can not exceed 15 sq. ft. for 1,000 lb.

Car Opening Configurations and Coding

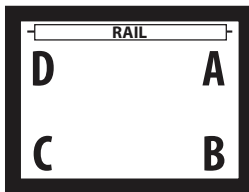
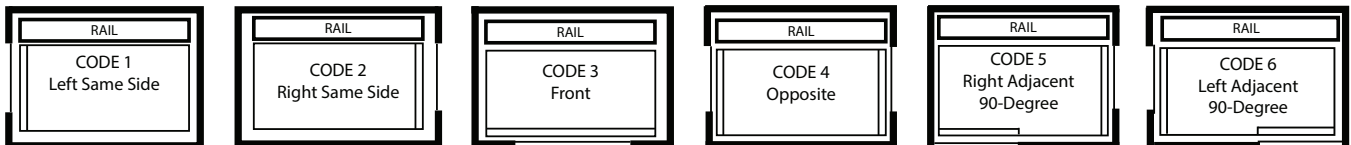

1. The DA is the side on which the rail is attached.
2. The first letter refers to the attachment location of the gate.
3. The second letter refers to the location of the strike plate.
4. If present, the third letter "R" denotes a recessed gate.

Example

First Gate - ABR

A - gate attachment
B - strike plate
R - recessed gate

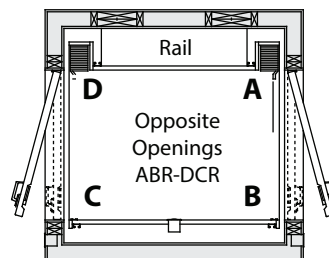

Second Gate - DCR

D - gate attachment
C - strike plate
R - recessed gate

Example Hoistway Layouts- Series 115 & 118

Construction Notes:

- Use specified rail backing from architect to frame into wall. Waupaca Elevator recommend LVL's.
- The hoistway illustrations below show finished dimensions. Finished hoistway dimensions include drywall, plaster, and paint.
- A maximum of 3/4" (see "g" below) are allowed between the closed hoistway door and the outer edge of the landing sill.
- Determine height of hall station by local code.
- Rough frame door in place with an extra inch of space on each side of the door to allow for door installation.

The following examples are of units up to 1,000 lbs. Elevators are illustrated with accordion gates. The following layouts were designed for travel up to 50 feet.

These symbols are listed beside the car size Waupaca Elevator believes to be best suited for use by wheelchair passengers and their accompanying attendant.



Recommended size for wheelchair passenger



Recommended size for both wheelchair and attendant passengers

DCR CODE 1

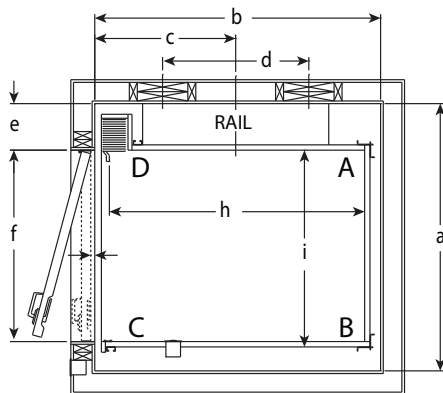

CDR CODE 1

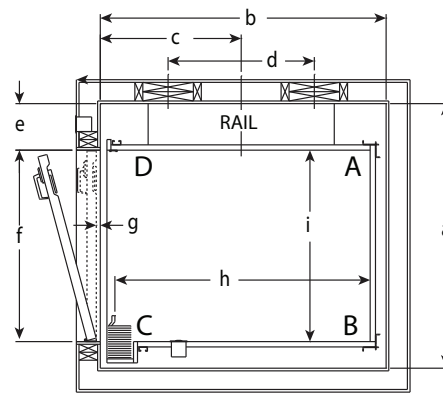

Hoistway Layout	Platform Area ID	Car Size	a	b	c	d	e	f	g	h	i
DCR Code 1	12 sq ft	48" X 36"	50.25"	53.75"	26.5"	27.5"	8.75"	36"	0.75"	48"	36"
	15 sq ft	54" X 40"	54.25"	59.75"	29.5"	27.5"	12.75"	36"	0.75"	54"	40"
	15 sq ft	60" X 36"	50.25"	65.75"	32.5"	27.5"	8.75"	36"	0.75"	60"	36"
CDR Code 1	12 sq ft	48" X 36"	51.25"	53.25"	26.5"	27.5"	8.75"	36"	0.75"	48"	36"
	15 sq ft	54" X 40"	53.75"	59.75"	29.5"	27.5"	8.75"	36"	0.75"	54"	40"
	15 sq ft	60" X 36"	51.25"	65.75"	32.5"	27.5"	8.75"	36"	0.75"	60"	36"

*All dimensions are finished hoistway dimensions

Example Hoistway Layouts- Series 115 & 118

ABR CODE 2

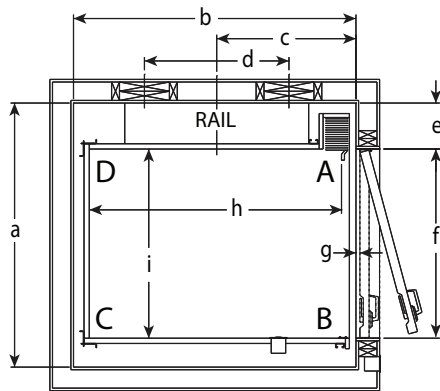

BAR CODE 2

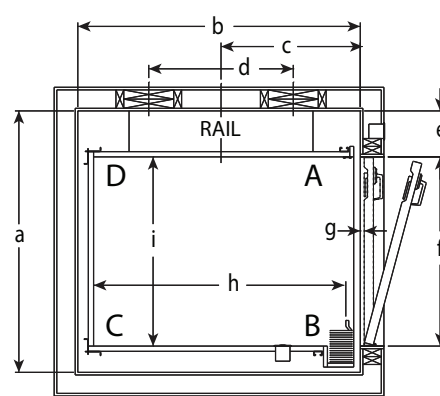

Hoistway Layout	Platform Area ID	Car Size	a	b	c	d	e	f	g	h	i
ABR Code 2	12 sq ft	48" X 36"	50.25"	53.75"	26.5"	27.5"	8.75"	36"	0.75"	48"	36"
	15 sq ft	54" X 40"	54.25"	59.75"	29.5"	27.5"	12.75"	36"	0.75"	54"	40"
	15 sq ft	60" X 36"	50.25"	65.75"	32.5"	27.5"	8.75"	36"	0.75"	60"	36"
BAR Code 2	12 sq ft	48" X 36"	51.25"	53.75"	26.5"	27.5"	8.75"	36"	0.75"	48"	36"
	15 sq ft	54" X 40"	53.75"	59.75"	29.5"	27.5"	8.75"	36"	0.75"	54"	40"
	15 sq ft	60" X 36"	51.25"	65.75"	32.5"	27.5"	8.75"	36"	0.75"	60"	36"

*All dimensions are finished hoistway dimensions

BC CODE 3

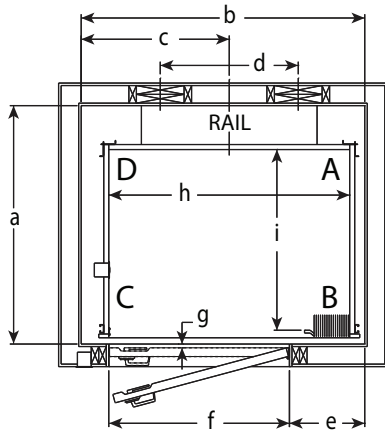

CB CODE 3

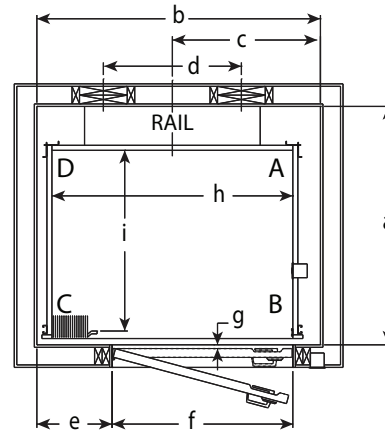

Hoistway Layout	Platform Area ID	Car Size	a	b	c	d	e	f	g	h	i
BC Code 3	12 sq ft	48" X 36"	47.5"	56.75"	29.5"	27.5"	15"	36"	0.75"	48"	36"
	15 sq ft	54" X 40"	51.5"	62.5"	32.5"	27.5"	21"	36"	0.75"	54"	40"
	15 sq ft	60" X 36"	47.5"	68.5"	35.5"	27.5"	27"	36"	0.75"	60"	36"
CB Code 3	12 sq ft	48" X 36"	47.5"	56.5"	29.5"	27.5"	15"	36"	0.75"	48"	36"
	15 sq ft	54" X 40"	51.5"	62.5"	32.5"	27.5"	21"	36"	0.75"	54"	40"
	15 sq ft	60" X 36"	47.5"	68.5"	35.5"	27.5"	27"	36"	0.75"	60"	36"

*All dimensions are finished hoistway dimensions

Example Hoistway Layouts- Series 115 & 118

ABR - DCR CODE 4

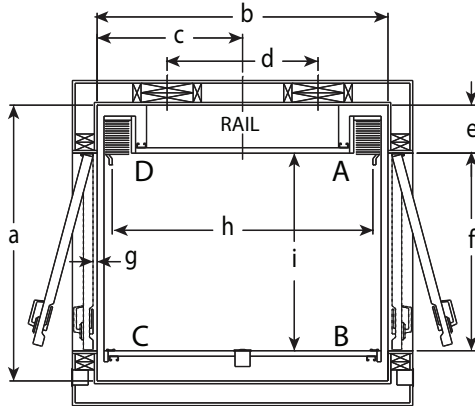

BAR - DCR CODE 4

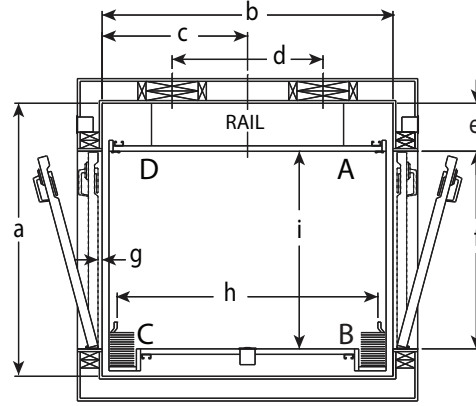

Hoistway Layout	Platform Area ID	Car Size	a	b	c	d	e	f	g	h	i
ABR- DCR Code 4	12 sq ft	48" X 36"	50.25"	53.5"	26.75"	27.5"	8.75"	36"	0.75"	48"	36"
	15 sq ft	54" X 40"	54.25"	59.5"	29.75"	27.5"	12.75"	36"	0.75"	54"	40"
	15 sq ft	60" X 36"	50.25"	65.5"	32.75"	27.5"	8.75"	36"	0.75"	60"	36"
BAR - CDR Code 4	12 sq ft	48" X 36"	51.25"	53.5"	26.75"	27.5"	8.75"	36"	0.75"	48"	36"
	15 sq ft	54" X 40"	53.75"	59.5"	29.75"	27.5"	8.75"	36"	0.75"	54"	40"
	15 sq ft	60" X 36"	51.25"	65.5"	32.75"	27.5"	8.75"	36"	0.75"	60"	36"

*All dimensions are finished hoistway dimensions

ABR - BC CODE 5

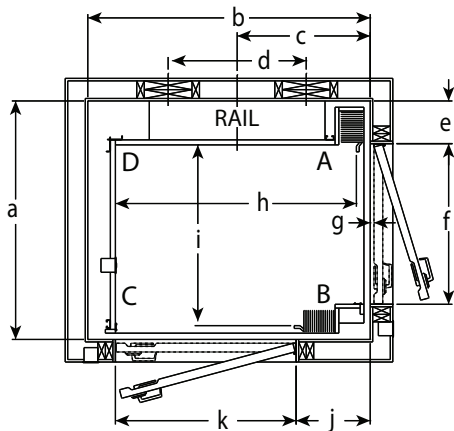

DCR - CB CODE 6

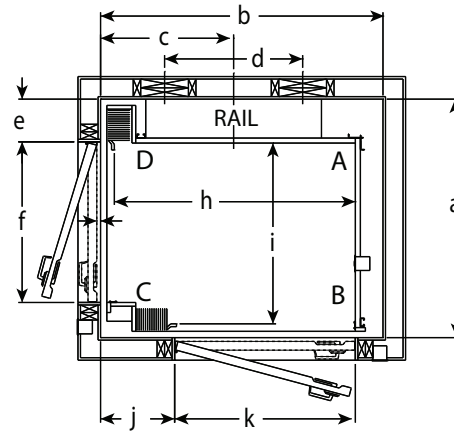

Hoistway Layout	Platform Area ID	Car Size	a	b	c	d	e	f	g	h	i	j	k
ABR-BC Code 5	12 sq ft	48" X 36"	47.5"	55.75"	26.5"	27.5"	8.5"	32"	0.75"	48"	36"	14.75"	36"
	15 sq ft	54" X 40"	51.5"	61.75"	29.5"	27.5"	8.5"	36"	0.75"	54"	40"	20.75"	36"
	15 sq ft	60" X 36"	47.5"	67.75"	32.5"	27.5"	8.5"	32"	0.75"	60"	36"	26.75"	36"
DCR-CB Code 6	12 sq ft	48" X 36"	47.5"	55.75"	26.5"	27.5"	8.5"	32"	0.75"	48"	36"	14.75"	36"
	15 sq ft	54" X 40"	51.5"	61.75"	29.5"	27.5"	8.5"	36"	0.75"	54"	40"	20.75"	36"
	15 sq ft	60" X 36"	47.5"	67.75"	32.5"	27.5"	8.5"	32"	0.75"	60"	36"	26.75"	36"

*All dimensions are finished hoistway dimensions

1726 North Ballard Road, Suite 1 • Appleton, WI 54911
Phone 920-991-9082 • www.waupacaelevator.com

PMQ1100-A
03 JAN 2020